



"time to heat up most efficiently"



2024

COLLECTION



WHO ARE WE ?

İfıyl Termo İklimlendirme San. ve Tic. Ltd. Şti. is a company that specializes in providing modern and innovative solutions in the field of heating systems. Since its establishment in 2009, the company has been focused on efficiency, energy saving, and comfort. With a 6,000 m² production area and a total area of 20,000 m², İfıyl Termo continues to produce environmentally friendly and high-quality products. The company has a dedicated R&D department that constantly improves itself and utilizes tomorrow's technology.

İfıyl Termo currently exports its products to over 20 countries due to increasing demands. The company's models are known for their unique ergonomic design, modern appearance, and compact mechanical structure.

İfıyl Termo is committed to sustainable production practices and adheres to international quality standards. With its maximum combustion technology, İfıyl ensures low fuel consumption and even heating throughout the home. Moreover, the inclusion of hot water comfort in İfıyl's products turns heating into a pleasurable experience.



Product Technical Specifications

Technical Data



Heat Output
(Nominal - Minimum)



Water Heating Power



Ambient Heating Power



Efficiency
(Nominal - Minimum)



Fuel Consumption
(Maximum - Minimum)



Fuel Tank Capacity



Maximum Heating
Volume



Product Weight



Chimney Diameter



Fireplace View



Heating Modulation



Digital Control Panel



Chorono
(Weekly Programing)



Room Thermostat



Auto Ignition



Thermal Safety Valve



Firing By Extractor Fan



Semi Auto Primary
Air Controller



Manuel Secondary
Air Controller



Radiators



Blowing Hot Air in
Ambiente Room



Canalizable
2nd Fan Outlet



Manuel Cleaning
Burning Pot



Auto Clean Burning pot



Tilting Grill
Cleaning System



Manuel Turbulator
Cleaning



Automatic Turbulator
Cleaning (Optional)



Automatic Ash
Cleaning (Optional)



Back Flame Safety



Sanitary Hot Water
Usage (Optional)

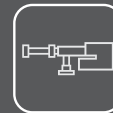

Anti Condensate Valve



Cooking Place On Top
Stove (Cast Iron – Steel)



Wide Chorome Oven
Functional



Front Load



Pellet Fuel Type



Wood Fuel Type



Briquette Fuel Type



Coal Fuel Type



Top Load

TROY

HYDRO PELLETT STOVE



COLOUR

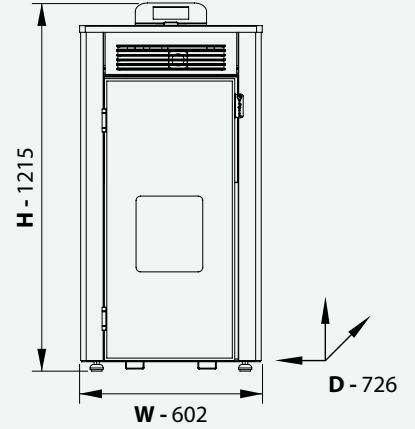

22,7 - 8,4 kW	19,4 kW	3,3 kW	91,7 - 94,1 %
5,25 - 1,89 kg / h	32 - 53 kg - lt	222 kg	Ø 100 mm

PRODUCT FEATURES

- Modulated combustion
- Digital control panel
- Automatic ignition
- Fully automatic cleaning of burning pot
- Manual turbulator cleaning system
- Combustion with extractor fan
- Weekly programming
- Room thermostat connection
- Back burn protection
- Support for blowing hot air into the environment
- Fireplace view
- Heating system
- Hot water heat exchanger (optional)
- Wi-Fi - Wireless connection (optional)
- Pellet fuelled

A⁺

DM186 Class 4

%100
Green Energy

PELLET SYSTEM

STYLISH DESIGN
MODERN HEATING
SOLUTIONS...

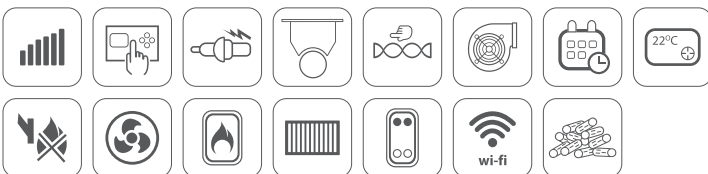

BlmSchV 2



CONTO TERMICO 2.0







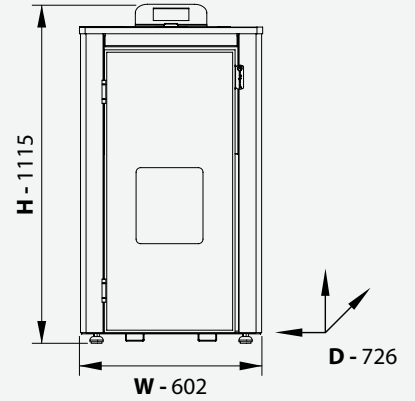

FREEDOM

HYDRO PELLET STOVE



COLOUR



 16 - 4,8 kW	 15 kW	 1 kW	 94,7 - 94,8 %
 3,5 - 1,05 kg / h	 25 - 42 kg - lt	 216 kg	 Ø 100 mm

PRODUCT FEATURES

- Modulated combustion
- Digital control panel
- Automatic ignition
- Fully automatic cleaning of burning pot
- Manual turbulator cleaning system
- Combustion with extractor fan
- Weekly programming
- Room thermostat connection
- Back burn protection
- Support for blowing hot air into the environment
- Fireplace view
- Heating system
- Hot water heat exchanger (optional)
- Wi-Fi - Wireless connection (optional)
- Pellet fuelled

A+

DM186 Class 5

%100
Green Energy

PELLET SYSTEM

STYLISH DESIGN
MODERN HEATING
SOLUTIONS...



CE EN 14785 BlmSchV 2  CONTO TERMICO 2.0

BOSPHORUS PLUS

HYDRO PELLET CUSINE STOVE



COLOUR

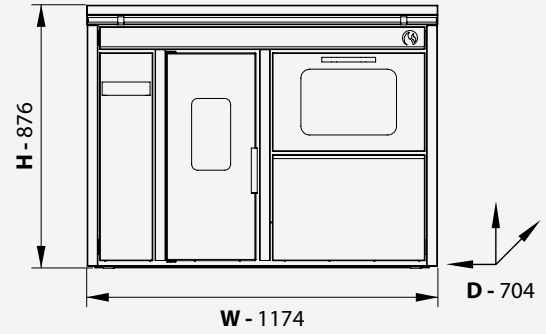

 22 - 6,6 kW	 14 kW	 8 kW	 92,6 - 95,7 %
 4,9 - 1,47 kg / h	 26 - 43 kg - lt	 265 kg	 Ø 100 mm

PRODUCT FEATURES

- Modulated combustion
- Digital control panel
- Automatic ignition
- Fully automatic cleaning of burning pot
- Manual turbulator cleaning system
- Combustion with extractor fan
- Weekly programming
- Room thermostat connection
- Back burn protection
- Cooking on ceramic glass
- Large, convenient chrome oven
- Soft close oven door
- Fireplace view
- Heating system
- Hot water heat exchanger (optional)
- Wi-Fi - Wireless connection (optional)
- Pellet fuelled

A⁺

DM186 Class 5

%100
Green Energy

PELLET SYSTEM

STYLISH DESIGN
MODERN HEATING
SOLUTIONS...



CE EN 16510 BlmSchV 2



CONTO TERMICO 2.0

BOSPHORUS PLUS

HYDRO PELLET CUSINE STOVE



COLOUR

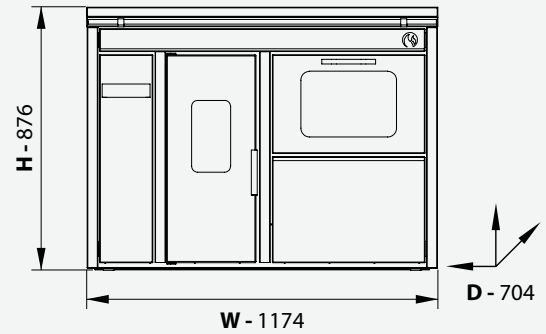

22 - 6,6 kW	14 kW	8 kW	92,6 - 95,7 %
4,9 - 1,47 kg / h	26 - 43 kg - lt	265 kg	Ø 100 mm

PRODUCT FEATURES

- Modulated combustion
- Digital control panel
- Automatic ignition
- Manually cleaned combustion pot
- Manual turbulator cleaning system
- Combustion with extractor fan
- Weekly programming
- Room thermostat connection
- Back burn protection
- Large, convenient chrome oven (3 levels)
- Soft close oven door
- Fireplace view
- Heating system
- Hot water heat exchanger (optional)
- Wi-Fi - Wireless connection (optional)
- Pellet fuelled

A⁺

DM186 Class 5

%100
Green Energy

PELLET SYSTEM

STYLISH DESIGN
MODERN HEATING
SOLUTIONS...



CE EN 16510 BImSchV 2



CONTO TERMICO 2.0

RUMELIA

COOKING PELLET STOVE (CANALIZABLE)



COLOUR

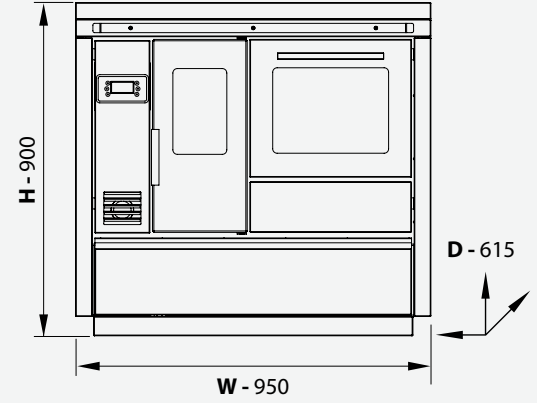

 9 - 3,8 kW	 86,6 - 88,1 %	 1,9 - 0,6 kg / h	 15 - 26 kg - lt
 156 kg	 Ø 80 mm	(*) Cihazın kuruluğu ortam şartlarına göre maksimum ısıtma hacmi değişiklik gösterebilir.	

PRODUCT FEATURES

- Modulated combustion
- Digital control panel
- Automatic ignition
- Manually cleaned combustion pot
- Combustion with extractor fan
- Weekly programming
- Room thermostat connection
- Back burn protection
- Cooking on ceramic glass
- Large, convenient chrome oven
- Soft close oven door
- Support for blowing hot air into the environment
- Multiple environment heating with air duct support
- Fireplace view
- Wi-Fi - Wireless connection (optional)
- Pellet fuelled

A+

%100
Green Energy

**PELLET
SYSTEM**

STYLISH DESIGN
MODERN HEATING
SOLUTIONS...



CE EN 16510

CRYSTAL TRIO

AIR PELLET STOVE (CANALIZABLE)



Hava kanalı
desteği ile
çoklu ortam
ısıtma imkanı



COLOUR

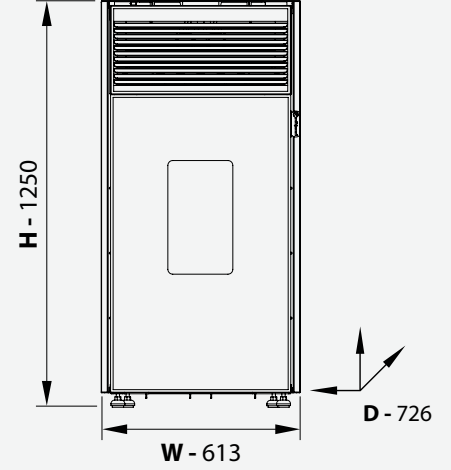

 16,3 - 3,2 kW	 87 - 90 %	 3,8 - 0,92 kg / h	 410 (*) m ³
 30 - 52 kg - lt	 192 kg	 Ø 80 mm	(*) Cihazın kurulduğu ortam şartlarına göre maksimum ısıtma hacmi değişiklik gösterebilir.

PRODUCT FEATURES

- Modulated combustion
- Digital control panel and Turkish menu
- Automatic ignition
- Manually cleaned combustion pot
- Combustion with extractor fan
- Weekly programming
- Room thermostat connection
- Back burn protection
- Support for blowing hot air into the environment (3 blowing fans)
- Multiple environment heating with air duct support
- Fireplace view
- Wi-Fi - Wireless connection (optional)
- Pellet fuelled

A⁺

%100
Green Energy

**PELLET
SYSTEM**

STYLISH DESIGN
MODERN HEATING
SOLUTIONS...

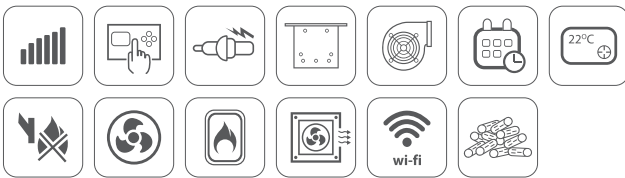

CE EN 14785

CRYSTAL COMFORT

AIR PELLET STOVE (CANALIZABLE)



COLOUR

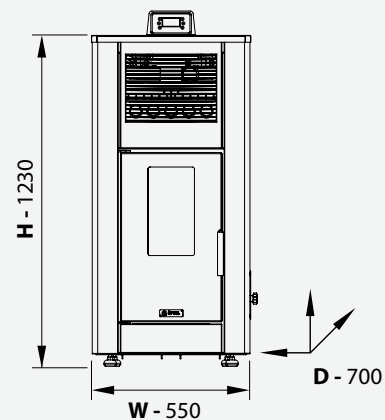

12,2 - 5,1 kW	85,6 - 94,4 %	1,1 - 2,9 kg / h	310 (*) m ³
23 - 38 kg - lt	149 kg	Ø 80 mm	(*) The maximum heating volume may depend on the ambient room conditions

PRODUCT FEATURES

- Modulated combustion
- Digital control panel
- Automatic ignition
- Manually cleaned combustion pot
- Combustion with extractor fan
- Weekly programming
- Room thermostat connection
- Back burn protection
- Support for blowing hot air into the environment (2 blowing fans)
- Multiple environment heating with air duct support
- Fireplace view
- Wi-Fi - Wireless connection (optional)
- Pellet fuelled

A+

DM186 Class 5

%100
Green Energy

PELLET SYSTEM

STYLISH DESIGN
MODERN HEATING
SOLUTIONS...

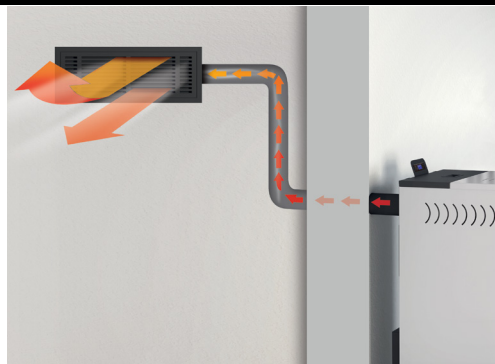
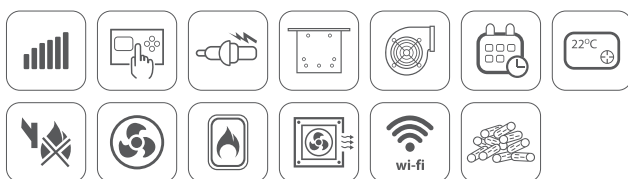

CE EN 14785 BlmSchV 2 CONTO TERMICO 2.0

CRYSTAL PLUS

AIR PELLET STOVE (CANALIZABLE)

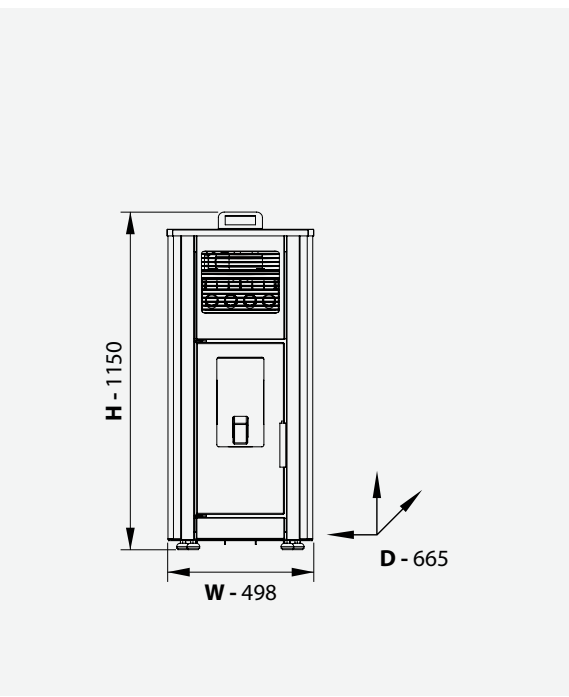

10 - 3 kW	10-12 kW	88 - 89 %	2,5 - 0,75 kg / h
287 (*) m ³	23 - 38 kg - lt	137 kg	Ø 80 mm

(*) The maximum heating volume may depend on the ambient room conditions

COLOUR

PRODUCT FEATURES

- Modulated combustion
- Digital control panel- Turkish menu
- Automatic ignition
- Manually cleaned combustion pot
- Combustion with extractor fan
- Weekly programming
- Room thermostat connection
- Back burn protection
- Support for blowing hot air into the environment (2 blowing fans)
- Multiple environment heating with air duct support
 - Fireplace view
 - Wi-Fi - Wireless connection (optional)
 - Pellet fuelled

A+
DM186 Class 5

%100
Green Energy



PELLET SYSTEM
STYLISH DESIGN
MODERN HEATING SOLUTIONS...
ECO DESIGN 2022

CE EN 14785 BlmSchV 2 CONTO TERMICO 2.0

THERMAL STANDART

AIR PELLET STOVE

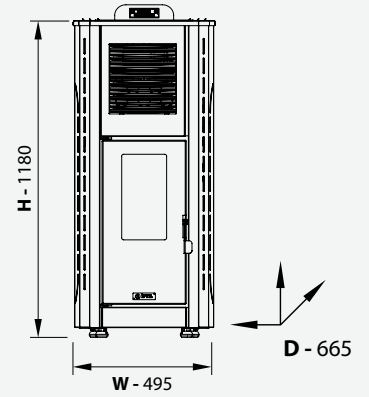

COLOUR



(*) The maximum heating volume may depend on the ambient room conditions

 8 - 2,4 kW	 8 - 10 kW	 88 - 89 %	 2,00 - 0,60 kg / h
 230 (*) m ³	 17 - 28 kg - lt	 127 kg	 Ø 80 mm

PRODUCT FEATURES

- Modulated combustion
- Digital control panel and Turkish menu
- Automatic ignition
- Manually cleaned combustion pot
- Combustion with extractor fan
- Weekly programming
- Room thermostat connection
- Back burn protection
- Support for blowing hot air into the environment
- Fireplace view
- Wi-Fi - Wireless connection (optional)
- Pellet fuelled

A⁺

DM186 Class 5

%100
Green Energy

PELLET SYSTEM

STYLISH DESIGN
MODERN HEATING
SOLUTIONS...

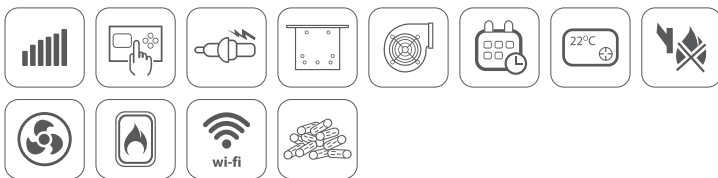

CE EN 14785 BImSchV 2



CONTO TERMICO 2.0

ADA

AIR PELLET STOVE



COLOUR

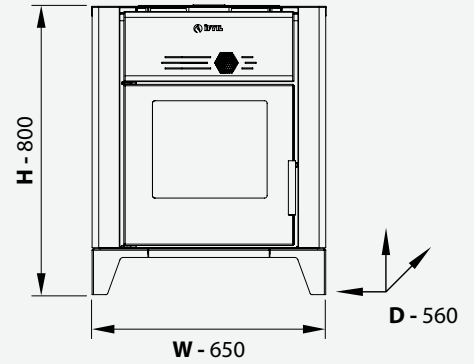

5,3 - 1,2 kW	85 - 89 %	1,1 - 0,3 kg / h	130 (*) m ³
15 - 26 kg - lt	94 kg	Ø 80 mm	(*) The maximum heating volume may depend on the ambient room conditions

PRODUCT FEATURES

- Modulated combustion
- Digital control panel and Turkish menu
- Automatic ignition
- Manually cleaned combustion pot
- Combustion with extractor fan
- Weekly programming
- Room thermostat connection
- Back burn protection
- Support for blowing hot air into the environment
- Fireplace view
- Wi-Fi - Wireless connection (optional)
- Pellet fuelled

A⁺

%100
Green Energy

PELLET SYSTEM

STYLISH DESIGN
MODERN HEATING
SOLUTIONS...

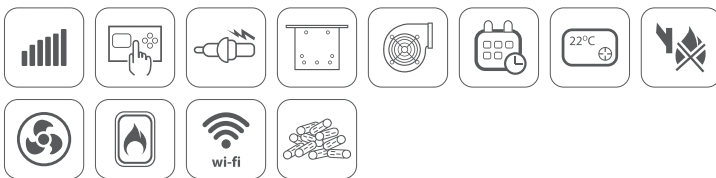

CE EN 14785





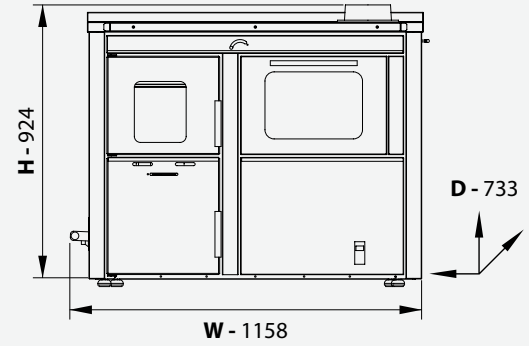

STAR

HYDRO COOKING WOOD STOVE



COLOUR



	Wood 23 kW	Briquette 24 kW	Coal 34,5 kW
	Wood 18 kW	Briquette 18 kW	Coal 27 kW
	Wood 5 kW	Briquette 6 kW	Coal 7,5 kW
	84,9 %		296 kg
			Ø 150 mm

PRODUCT FEATURES

- Tilting grill cleaning system
- Semi-automatic primary combustion air control
- Manual secondary combustion air control
- Safety device with safety valve
- Cooking on the top plate
- Large, convenient chrome oven
- Fireplace view
- Front and top loading
- Heating system
- Hot water heat exchanger (optional)
- Wood, briquette and coal burning

A+

DM186 Class 5

**FOUR
POWERFUL
ADVANTAGES**
CENTRAL HEATING
HOT WATER
STOVE & FIREPLACE



CE EN 16510 BImSchV 2



CONTO TERMICO 2.0

AVANOS

HYDRO COOKING WOOD STOVE



COLOUR

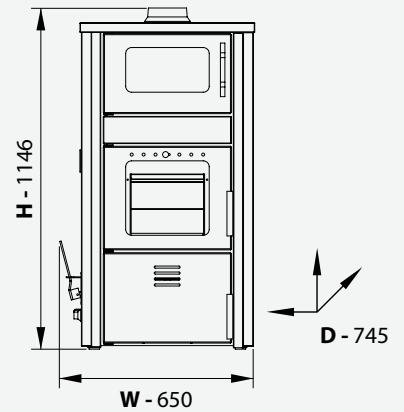

kW	Wood 20 kW	Briquette 21 kW	Coal 32 kW
	Wood 16 kW	Briquette 17 kW	Coal 26 kW
	Wood 4 kW	Briquette 4 kW	Coal 6 kW
 83 %	 229 kg	 Ø 130 mm	

PRODUCT FEATURES

- Tilting grill cleaning system
- Semi-automatic primary combustion air control
- Manual secondary combustion air control
- Safety device with safety valve
- Cooking on the top plate
- Large, convenient chrome oven
- Fireplace view
- Front loading
- Heating system
- Hot water heat exchanger (optional)
- Wood, briquette and coal burning

A⁺
DM186 Class 4

**FOUR
POWERFUL
ADVANTAGES**
CENTRAL HEATING
HOT WATER
STOVE & FIREPLACE



CE EN 16510 BImSchV 2



CONTO TERMICO 2.0







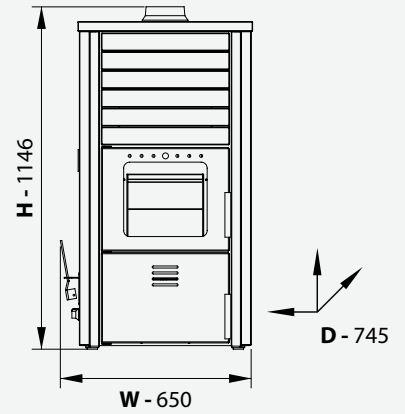

SUPERNOVA

HYDRO WOOD STOVE



COLOUR



	Wood 29 kW	Briquette 30 kW	Coal 38 kW
	Wood 25 kW	Briquette 26 kW	Coal 34 kW
	Wood 4 kW	Briquette 4 kW	Coal 4 kW
	84 %		
	211 kg		
		Ø 130 mm	

PRODUCT FEATURES

- Tilting grill cleaning system
- Semi-automatic primary combustion air control
- Manual secondary combustion air control
- Safety device with safety valve
- Cooking on the top plate
- Fireplace view
- Front loading
- Heating system
- Hot water heat exchanger (optional)
- Wood, briquette and coal burning

A⁺

DM186 Class 4

**FOUR
POWERFUL
ADVANTAGES**
CENTRAL HEATING
HOT WATER
STOVE & FIREPLACE



CE EN 16510 BImSchV 2



CONTO
TERMICO 2.0





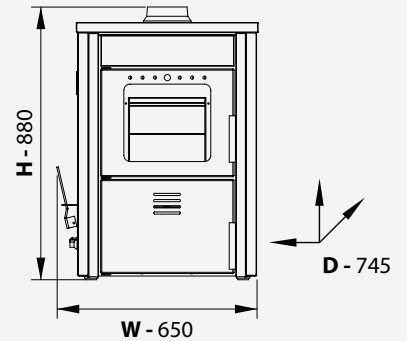

HAMMAM PLUS

HYDRO WOOD STOVE



COLOUR



	Wood 20 kW	Briquette 21 kW	Coal 32 kW
	Wood 16 kW	Briquette 17 kW	Coal 26 kW
	Wood 4 kW	Briquette 4 kW	Coal 6 kW
	83 %		180 kg
			Ø 130 mm

PRODUCT FEATURES

- Tilting grill cleaning system
- Semi-automatic primary combustion air control
- Manual secondary combustion air control
- Safety device with safety valve
- Cooking on the top plate
- Fireplace view
- Front and top loading
- Heating system
- Hot water heat exchanger (optional)
- Wood, briquette and coal burning

A⁺
DM186 Class 4

FOUR POWERFUL ADVANTAGES
CENTRAL HEATING
HOT WATER
STOVE & FIREPLACE



CE EN 16510 BImSchV 2  CONTO TERMICO 2.0



HAMMAM STANDART

HYDRO WOOD STOVE



COLOUR

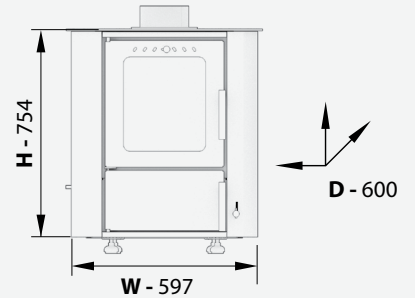

	Wood 13 kW
	Wood 10 kW
	Wood 3 kW
	80 %
	90 kg
	Ø 130 mm

PRODUCT FEATURES

- Tilting grill cleaning system
- Semi-automatic primary combustion air control
- Manual secondary combustion air control
- Safety device with safety valve
- Cooking on the top plate
- Fireplace view
- Front and top loading
- Heating system
- Hot water heat exchanger (optional)
- Wood burning

A+

DM186 Class 4

**FOUR
POWERFUL
ADVANTAGES**
CENTRAL HEATING
HOT WATER
STOVE & FIREPLACE



CE EN 16510 BImSchV 2





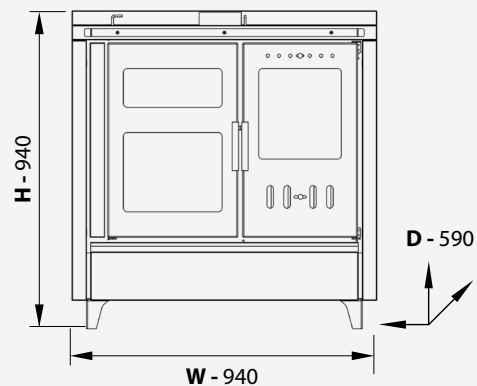

CONTO TERMICO 2.0

SUMELA

COOKING WOOD STOVE



	Wood 12,5 kW
	81,5 %
	170 kg
	Ø 130 mm

COLOUR



PRODUCT FEATURES

- Sliding grill cleaning system
- Manual primary combustion air control
- Manual secondary combustion air control
- Cooking on the top plate
- Large, handy 2 pieces chrome oven (with cooking stone)
- Fireplace view
- Front and top loading
- Wood, briquette and coal burning
- Ducted fan (optional)

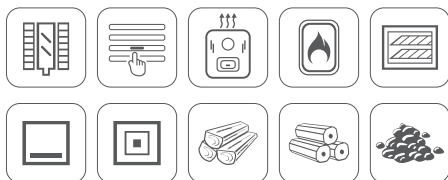

CE EN 16510







URGUP

COOKING WOOD STOVE

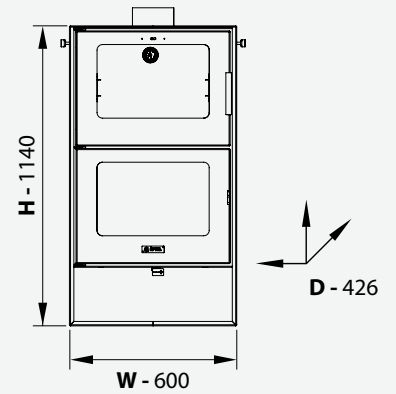

COLOUR



	Wood 6,1 kW
	80 %
	125 kg
	Ø 150 mm

PRODUCT FEATURES

- Manual primary combustion air control
- Manual secondary combustion air control
- Cooking on the top plate
- Large, handy chrome oven (3 levels with cooking stone)
- Fireplace view
- Front loading
- Wood, briquette and coal burning

A⁺

DM186 Class 4

NEW product

ECO DESIGN 2022

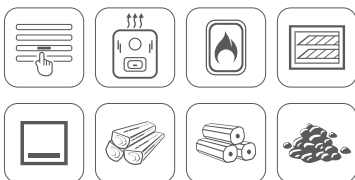

CE EN 16510

GT 15 DELUXE

PELLET BOILER



COLOUR

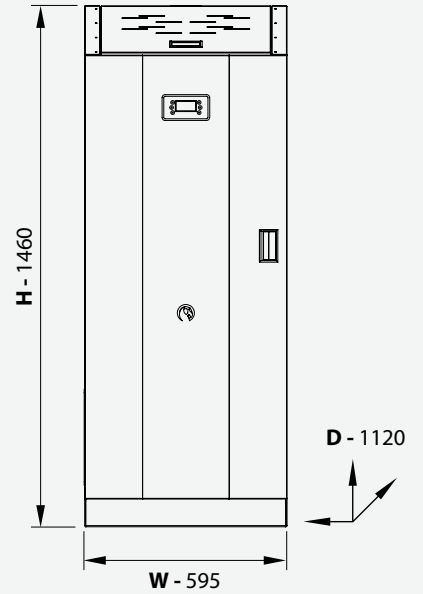

15 - 4,5 kW	15 kW	91,53 - 91,64 %	3,5 - 1,05 kg / h
135 - 230 kg - lt	231 kg	Ø 100 mm	

PRODUCT FEATURES

- Modulated combustion
- Digital control panel
- Automatic ignition
- Fully automatic cleaning of the combustion pot
- Manual turbulator cleaning system
- Automatic turbulator cleaning system (optional)
- Combustion with extractor fan
- Weekly programming
- Room thermostat connection
- Back burn protection
- Heating system
- Hot water heat exchanger (optional)
- Wi-Fi - Wireless connection (optional)
- Pellet fuelled
- Summer and Winter Mode (optional)

A⁺

EN 303-5 Class 5
DM186 Class 4

%100
Green Energy

PELLET SYSTEM

STYLISH DESIGN
MODERN HEATING
SOLUTIONS...



BlmSchV 2



CONTO TERMICO 2.0

GT 25 DELUXE

PELLET BOILER



COLOUR

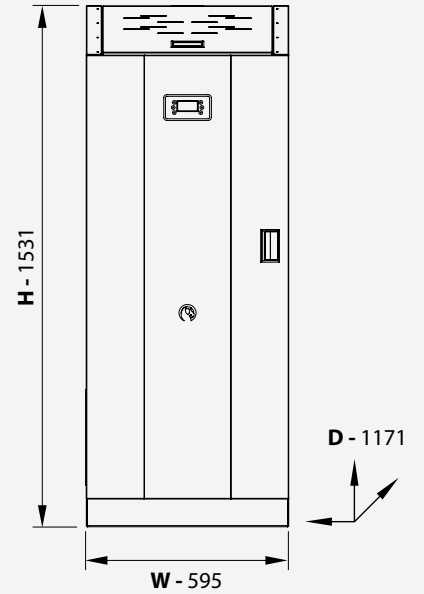

25 - 7,5 kW	25 kW	91,7 - 92,4 %	5,7 - 1,7 kg / h
135 - 230 kg - lt	280 kg	Ø 100 mm	

PRODUCT FEATURES

- Modulated combustion
- Digital control panel
- Automatic ignition
- Fully automatic cleaning of the combustion pot
- Manual turbulator cleaning system
- Automatic turbulator cleaning system (optional)
- Combustion with extractor fan
- Weekly programming
- Room thermostat connection
- Back burn protection
- Heating system
- Hot water heat exchanger (optional)
- Wi-Fi - Wireless connection (optional)
- Pellet fuelled
- Summer and Winter Mode (optional)

A+

EN 303-5 Class 5
DM186 Class 4

%100
Green Energy

PELLET SYSTEM

STYLISH DESIGN
MODERN HEATING
SOLUTIONS...



BlmSchV 2



CONTO TERMICO 2.0

GT 34 DELUXE

PELLET BOILER



COLOUR

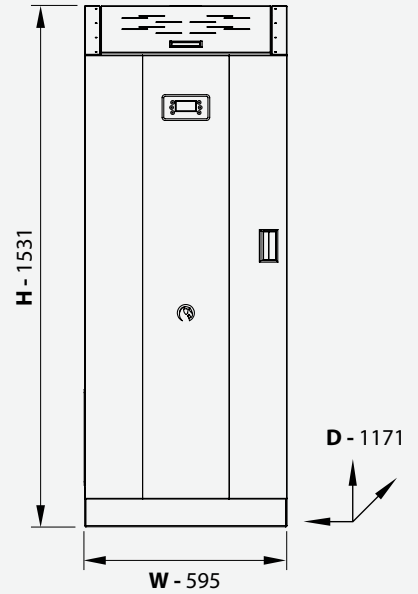

34 - 10,2 kW	34 kW	83,5 - 85 %	2,4 - 7,1 kg / h
135 - 230 kg - lt	280 kg	Ø 100 mm	

PRODUCT FEATURES

- Modulated combustion
- Digital control panel
- Automatic ignition
- Fully automatic cleaning of the combustion pot
- Manual turbulator cleaning system
- Automatic turbulator cleaning system (optional)
- Combustion with extractor fan
- Weekly programming
- Room thermostat connection
- Back burn protection
- Heating system
- Hot water heat exchanger (optional)
- Wi-Fi - Wireless connection (optional)
- Pellet fuelled
- Summer and Winter Mode (optional)

A⁺

EN 303-5 Class 5
DM186 Class 4

%100
Green Energy

PELLET SYSTEM

STYLISH DESIGN
MODERN HEATING
SOLUTIONS...



BlmSchV 2



CONTO TERMICO 2.0

GT 40

PELLET BOILER



COLOUR

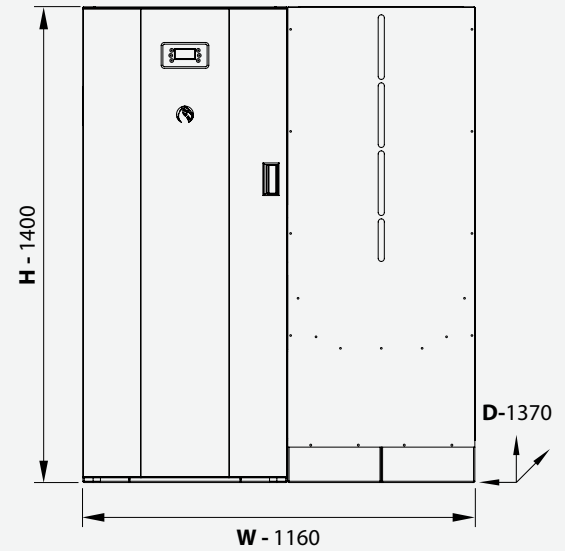

40 - 12 kW	40 kW	92 - 93,1 %	9,35 - 2,7 kg / h
253 - 420 kg - lt	310 + 100 kg	Ø 100 mm	

PRODUCT FEATURES

- Modulated combustion
- Digital control panel
- Automatic ignition
- Fully automatic cleaning of the combustion pot
- Manual turbulator cleaning system
- Combustion with extractor fan
- Weekly programming
- Room thermostat connection
- Back burn protection
- Heating system
- Hot water heat exchanger (optional)
- Wi-Fi - Wireless connection (optional)
- Pellet fuelled
- Summer and Winter Mode (optional)

A⁺

EN 303-5 Class 5
DM186 Class 4

%100
Green Energy

PELLET SYSTEM

STYLISH DESIGN
MODERN HEATING
SOLUTIONS...



BlmSchV 2



CONTO
TERMICO 2.0

GT 60

PELLET BOILER



COLOUR

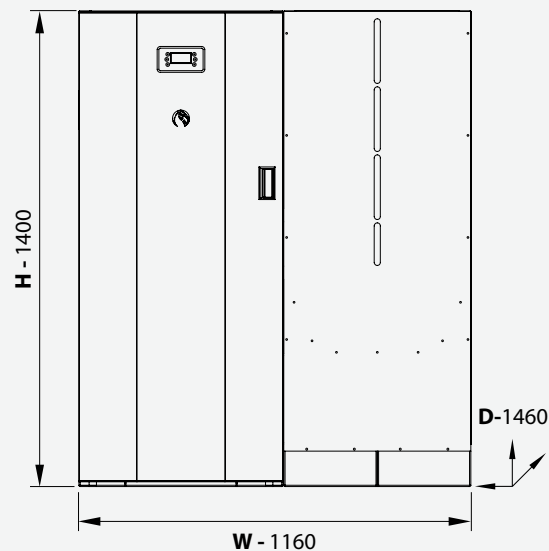

60 - 18 kW	60 kW	92 - 94,19 %	14 - 4,2 kg / h
340 - 567 kg - lt	424 + 107 kg	Ø 130 mm	

PRODUCT FEATURES

- Modulated combustion
- Digital control panel
- Automatic ignition
- Fully automatic cleaning of the combustion pot
- Manual turbulator cleaning system
- Combustion with extractor fan
- Weekly programming
- Room thermostat connection
- Back burn protection
- Heating system
- Hot water heat exchanger (optional)
- Wi-Fi - Wireless connection (optional)
- Pellet fuelled
- Summer and Winter Mode (optional)

A⁺

EN 303-5 Class 5
DM186 Class 4

%100
Green Energy

PELLET SYSTEM

STYLISH DESIGN
MODERN HEATING
SOLUTIONS...



BlmSchV 2



CONTO TERMICO 2.0

PWR 100

INDUSTRIAL TYPE HOT AIR BOILER

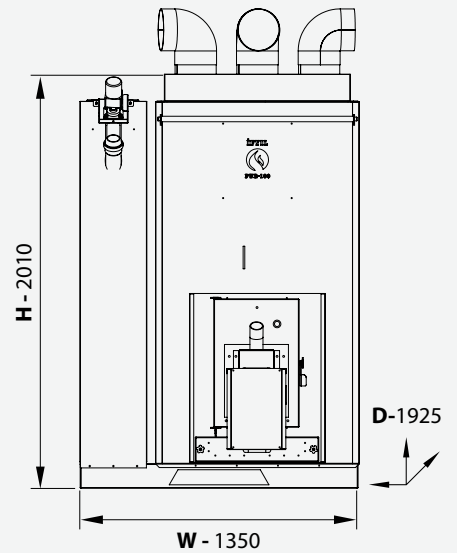

COLOUR

100 - 30 kW	90,5 - 91,5 %	17,5 - 5,5 kg / h
200 - 366 kg - lt	550 kg	Ø 130 mm

PRODUCT FEATURES

- Modulated combustion
- Digital control panel
- Automatic ignition
- Fully automatic cleaning of the combustion pot (optional)
- Manual turbulator cleaning system
- Combustion with extractor fan
- Weekly programming
- Room thermostat connection
- Back burn protection
- Wi-Fi - Wireless connection (optional)
- Pellet fuelled

A⁺

%100
Green Energy

PELLET SYSTEM

STYLISH DESIGN
MODERN HEATING
SOLUTIONS...



CE EN 303-5

RENEWABLE ENERGY

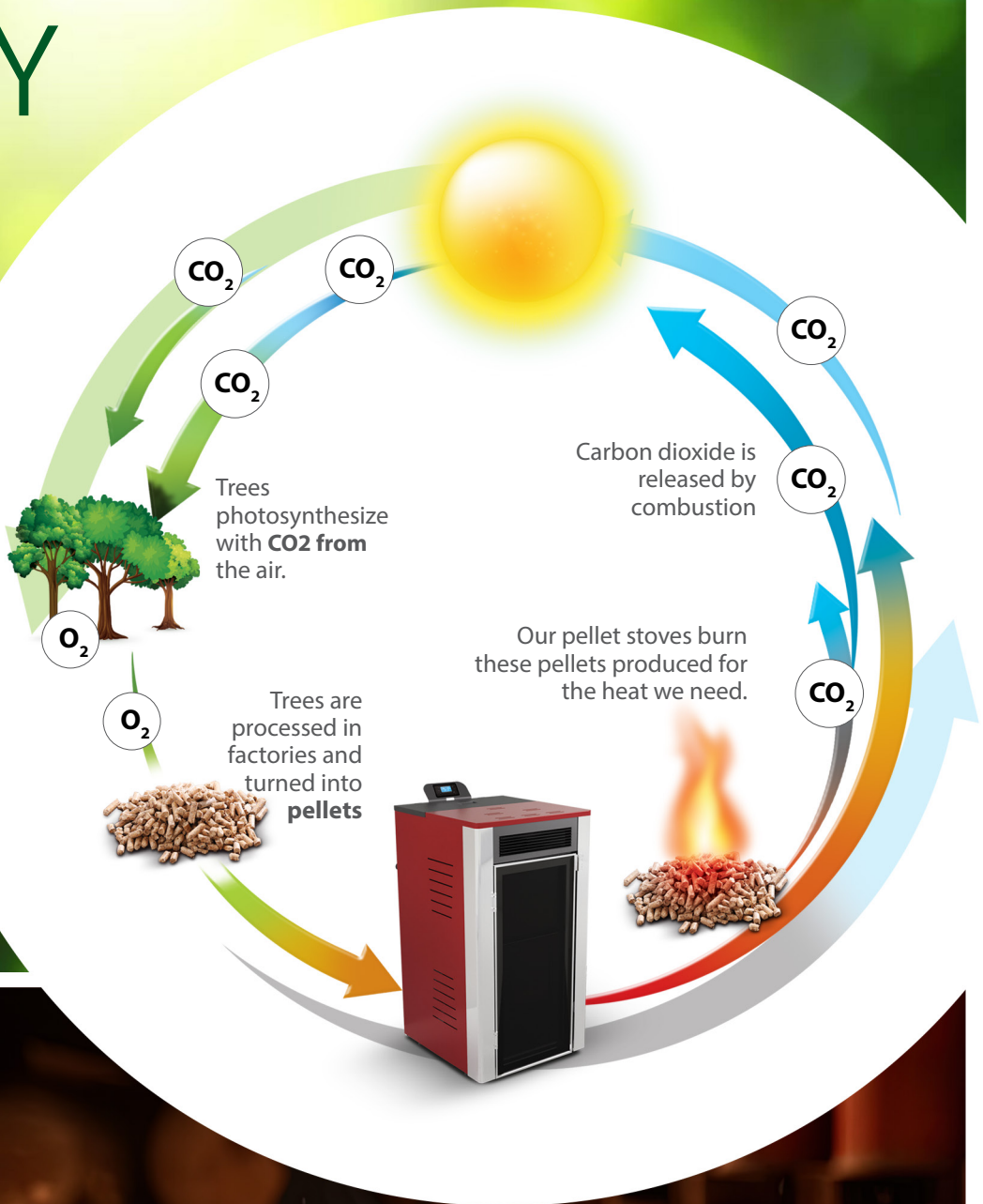

What is Pellet?

Pellets are fuel particles used to obtain energy, which are formed by grinding forest and vegetable residues into sawdust powder and then pressing and compressing them with high pressure. It is a type of fuel that has a small cylindrical form, usually 6-10 mm in diameter and 10-50 mm in length.



TROY PLUS

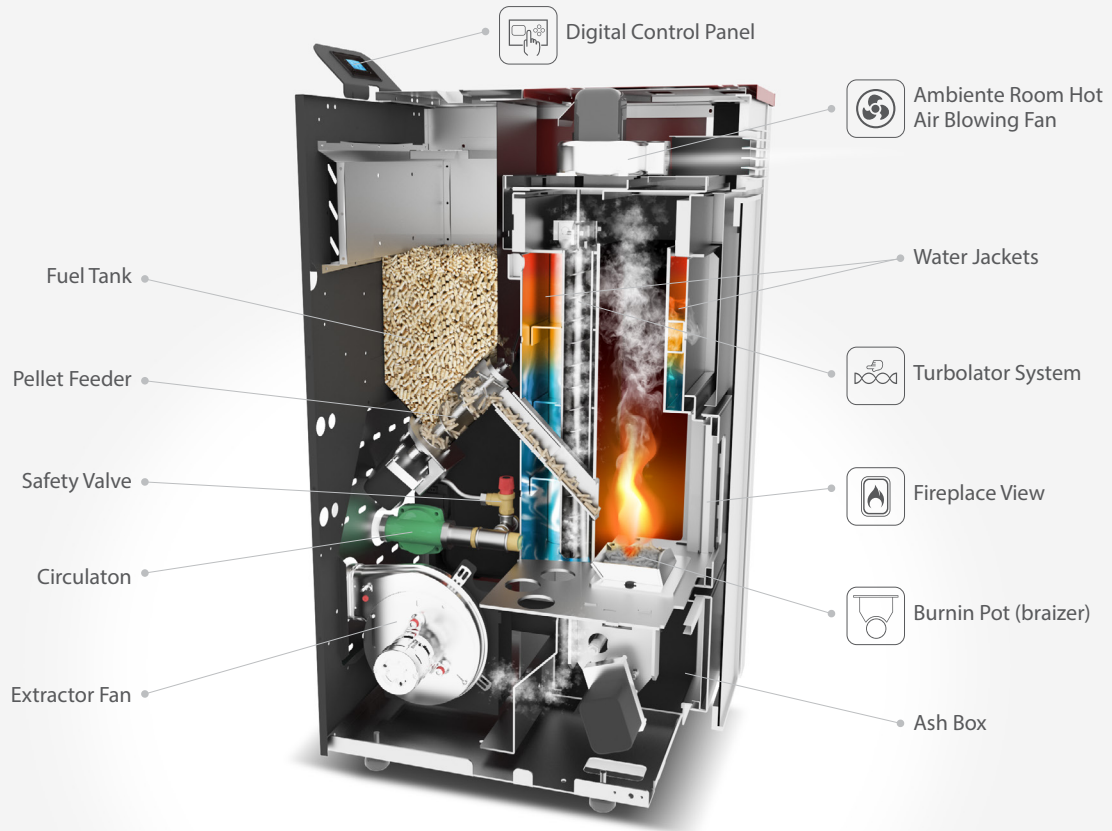

ROASTER

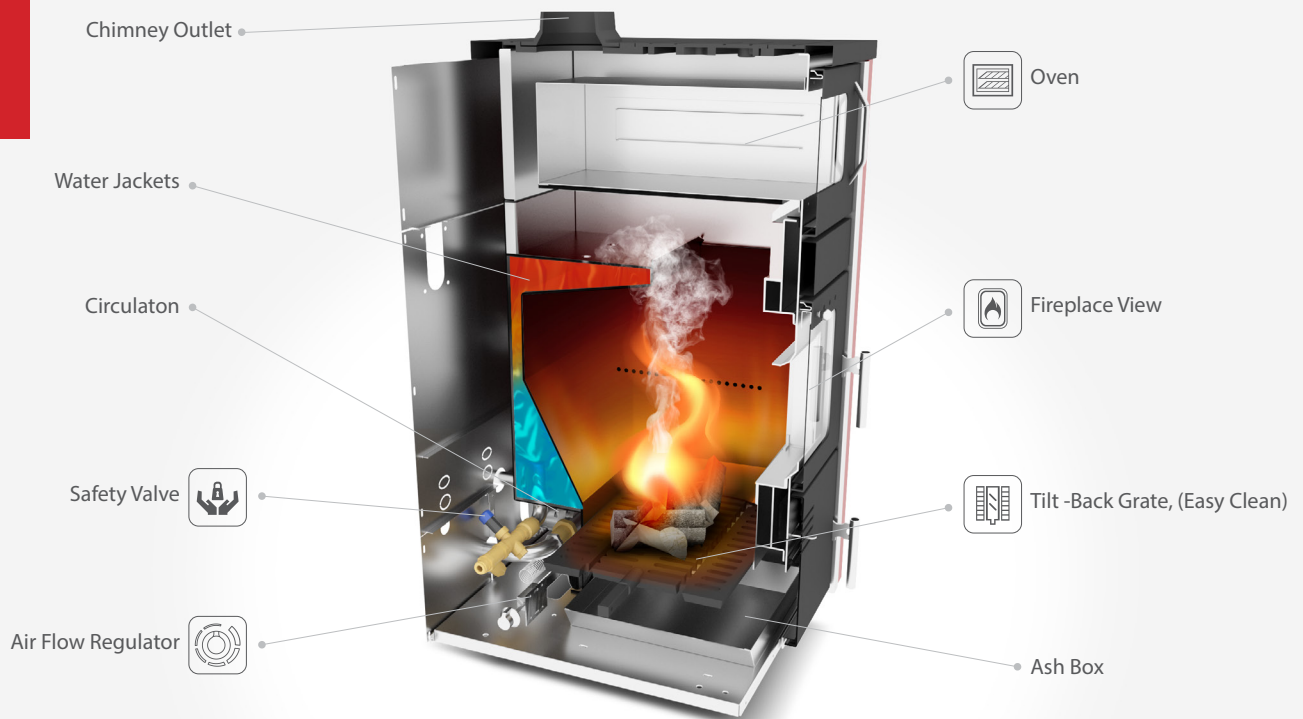

CRYSTAL PLUS

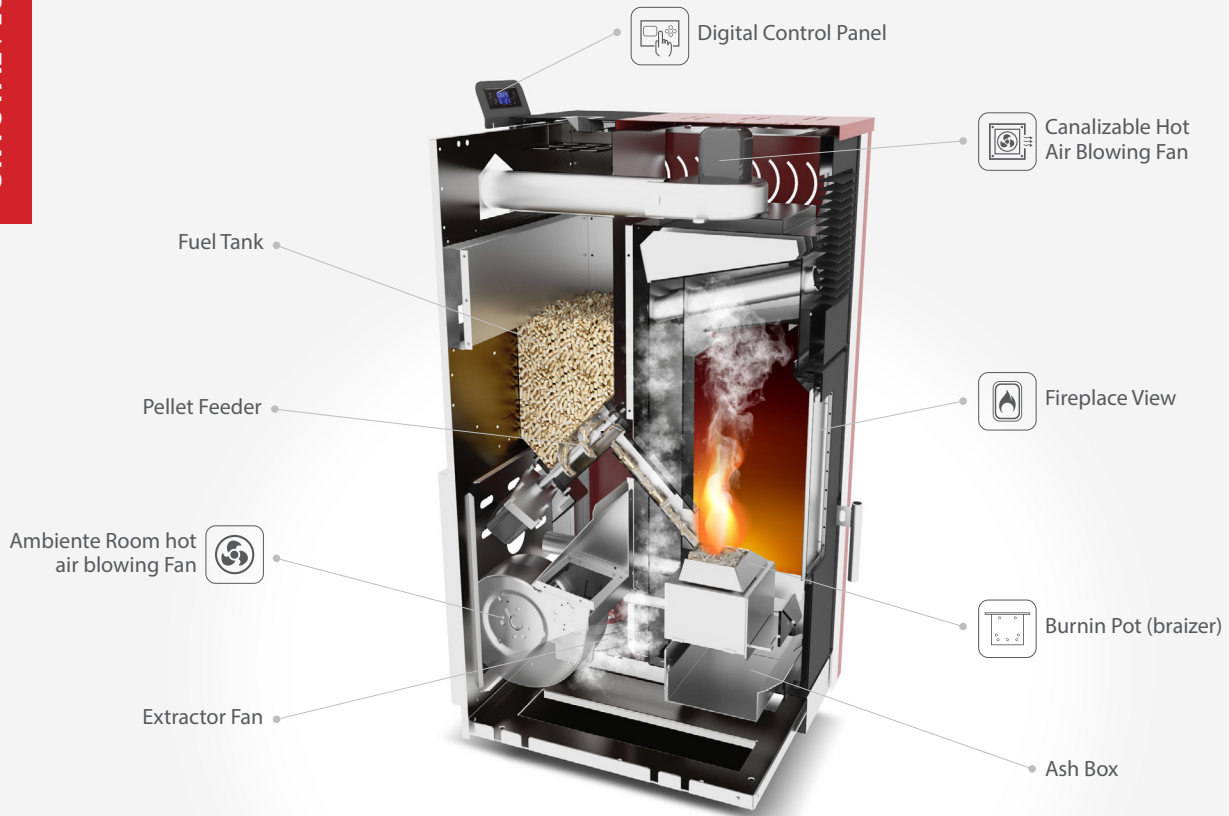

GT 60

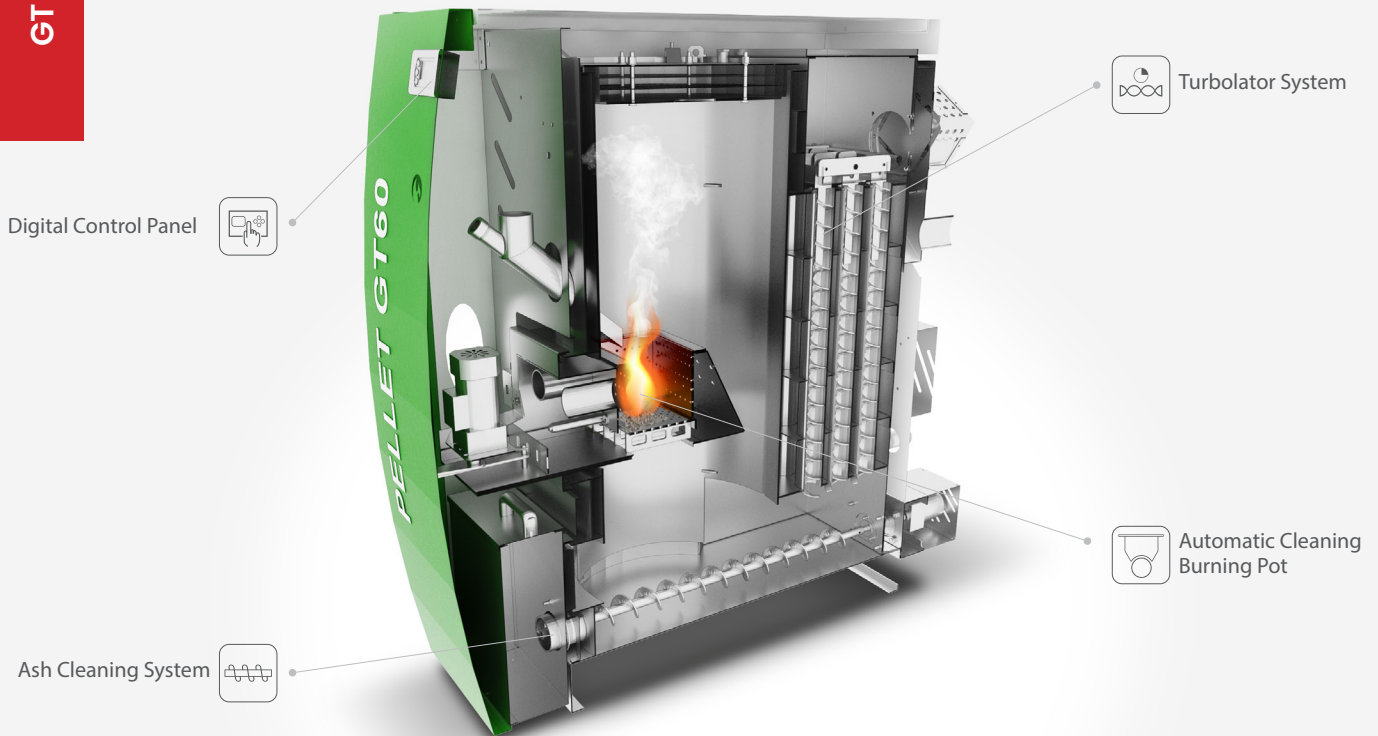



"Ifyil for healthy and quality living spaces"



Economical and Comfortable...

The fuel cost of Ifyil stoves is close to the fuel cost of a normal stove. The difference of Ifyil is that it does not heat only one room compared to a normal stove, but all parts of the house equally through radiators. You will enjoy hot water in your bathroom, sink and kitchen while providing equal temperature throughout your home!

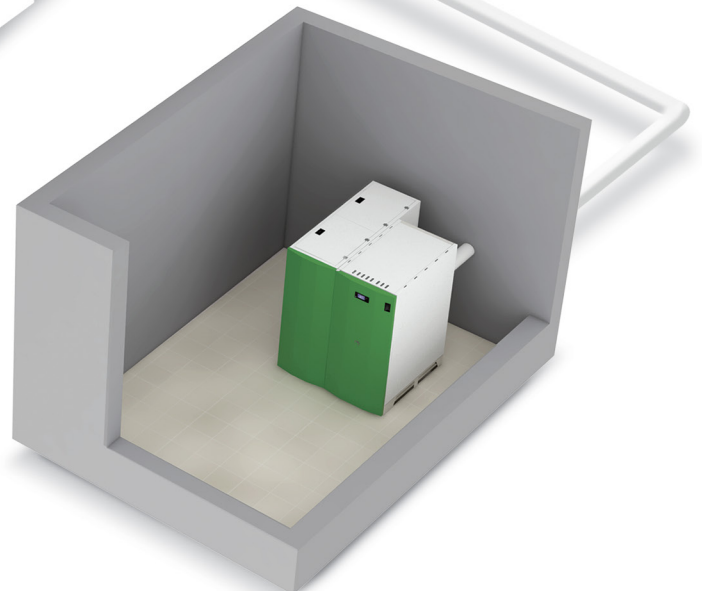

The ideal width of the chimney = 13-18 cm

Roof ridge should be minimum 80 cm

Fill the space in this area in an airtight manner.

5-6cm

THE SUITABLE CHIMNEY DIAGRAM FOR IFYIL STOVES



"time to heat up most efficiently"



Ifyil is not responsible for typographic mistakes and discolorations.
ifyil reserves the right to make changes to its products at any/ye time

YEŞİL ENERJİYİ SEÇMEK



2024
COLLECTION



**ifyil Termo İklimlendirme
San. ve Tic. Ltd. Şti.**



Kavak Organize Sanayi Bölgesi 3. Cadde
No.11 Kavak | Samsun | Türkiye

T +90 850 346 0362
www.ifyil.com.tr

f @ y in d
info@ifyil.com.tr

