



IFYIL®

"ortam ısıtıcınız"



2024

COLLECTION



www.ifyil.com.tr



BİZ KİMİZ?

İfyıl Termo İklimlendirme San. ve Tic. Ltd. Şti. 2009 yılından itibaren ısıtma sistemleri alanında modern ve yenilikçi çözümler sunmaya devam etmektedir. İfyıl Termo fabrikası toplam 20.000 m2 alan üzerinde 6.000 m2 kapalı üretim alanında üretimini sürdürmektedir. 50 deneyimli personeli ve paydaşlarıyla, sürekli kendini geliştiren, yarının teknolojisini kullanarak en iyi sonuca ulaşmayı hedefleyen Ar-Ge bölümüyle, verimlilik, enerji tasarrufu ve konfor anlayışlarını kendisine ilke edinmiştir.

İfyıl Termo artan taleplerle halihazırda 20'den fazla ülkeye ihracat yapmaktadır. "İfyıl Kalitesi" çevre dostu modelleriyle her geçen gün daha geniş bir coğrafyada dünyayı kucaklamaktadır. İfyıl modelleri benzersiz ergonomik tasarımı ve modern görünümü yanında kompakt, mekanik yapısı ile müşterilerine hizmet vermektedir.

İfyıl en son teknolojiyi kullanırken geleneksel hatları da kucaklamaktadır. İfyıl, üretimin her aşamasında uluslararası standartlara uygun olarak test ve kalite kontrolü yaparak, çevreye duyarlı, doğa ile dost ürünler üretmektedir.

Maksimum yanma teknolojisi sayesinde tüm evinizi eşit oranda ısıtarak düşük yakıt tasarrufu sağlamanın yanı sıra sıcak su konforunu da içinde barındırması, İFYİL'in ısınmayı bir ihtiyaçtan keyfe dönüştürmesinin kanıtıdır.



Ürün Teknik Özellikleri

Teknik Veri



Isı Çıkışı
(Nominal - Minimum)



Su Isıtma Gücü



Ortam Isıtma Gücü



Verim
(Nominal - Minimum)



Yakıt Tüketimi
(Maksimum - Minimum)



Yakıt Tankı Kapasitesi



Maksimum Isıtma
Hacmi



Ürün Ağırlığı



Baca Çapı



Şömine Görünümü



Modülyasyonlu Yanma



Dijital Kontrol Paneli
(Türkçe Menü)



Haftalık Programlama



Oda Termostat
Bağlantısı



Otomatik Ateşleme



Emniyet Ventilli
Güvenlik Tertibatı



Bacadan Emiş ile
Yanma



Yarı Otomatik Birincil
Yanma Havaşı Kontrol



Manuel İkincil
Yanma Havaşı Kontrol



Kalorifer Sistemi



Ortama Sıcak Hava
Üfleme Desteği



Hava Kanalı Desteği
İle Çoklu Ortam Isıtma



Manuel Temizlenen
Yanma Potası



Tam Otomatik
Temizlenen Yanma
Potası



Devirmeli Izgara
Temizleme Sistemi



Manuel Türbülötör
Temizleme Sistemi



Otomatik Türbülötör
Temizleme Sistemi



Otomatik Kül
Temizleme Sistemi
(Opsiyonel)



Geriye Yanma
Koruması



Sıcak Su Eşanjörü
(Opsiyonel)

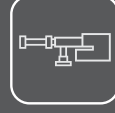

Anti Kondens Vana



Üst Tabla Üzerinde
Yemek Pişirme İmkanı



Geniş Kullanışlı
Krom Fırın



Önden Yüklemeli



Üstten Yüklemeli



Pelet Yakıtlı



Odun Yakıtlı



Briket Yakıtlı



Kömür Yakıtlı

TRUVA

KALORİFERLİ, PELET YAKITLI SOBA



RENK

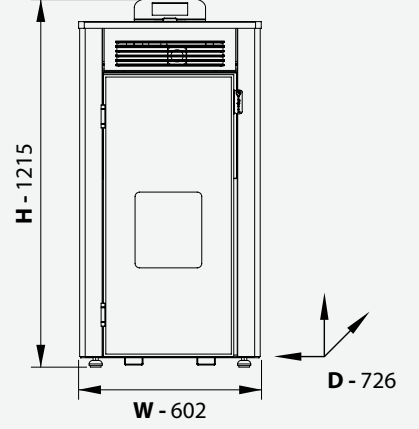

 22,7 - 8,4 kW	 19,4 kW	 3,3 kW	 91,7 - 94,1 %
 5,25 - 1,89 kg / h	 32 - 53 kg - lt	 222 kg	 Ø 100 mm

ÜRÜN ÖZELLİKLERİ

- Modülasyonlu yanma
- Dijital kontrol paneli ve Türkçe menü
- Otomatik ateşleme
- Tam otomatik temizlenen yanma potası
- Manuel tübülötör temizleme sistemi
- Bacadan emiş ile yanma
- Haftalık programlama
- Oda termostat bağlantısı
- Geriye yanma koruma
- Ortama sıcak hava üfleme desteği
- Şömine görünümü
- Kalorifer sistemi
- Sıcak su eşanjörü (opsiyonel)
- Wi-Fi - Kablosuz bağlantı (opsiyonel)
- Pelet yakıtlı

A⁺

DM186 Class 4

%100
yeşil enerji

PELET
SİSTEM

MODERN TASARIM
ÇAĞDAŞ ISINMA
ÇÖZÜMLERİ



IMQ
primacontrol

CE EN 14785

BlmSchV 2



CONTO
TERMICO 2.0

ABANT

KALORİFERLİ, PELET YAKITLI SOBA

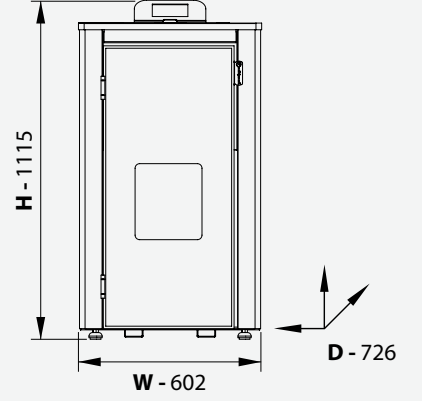

 16 - 4,8 kW	 15 kW	 1 kW	 94,7 - 94,8 %
 3,5 - 1,05 kg / h	 25 - 42 kg - lt	 216 kg	 Ø 100 mm

RENK

- Wi-Fi ile uzaktan bağlanma (opsiyonel)
- Modülasyonlu yanma
- Dijital kontrol paneli ve Türkçe menü
- Otomatik ateşleme
- Tam otomatik temizlenen yanma potası
- Manuel türbülötör temizleme sistemi
- Bacadan emiş ile yanma
- Haftalık programlama
- Oda termostat bağlantısı
- Geriye yanma koruma
- Şömine görünümü
- Kalorifer sistemi
- Sıcak su eşanjörü (opsiyonel)
- Pelet yakıtlı

A⁺

DM186 Class 5

%100
yeşil enerji

PELET
SİSTEM

MODERN TASARIM
ÇAĞDAŞ ISINMA
ÇÖZÜMLERİ



CE EN 14785 BlmSchV 2



CONTO
TERMICO 2.0

GALATA PLUS

KALORİFERLİ PELET KUZİNESİ

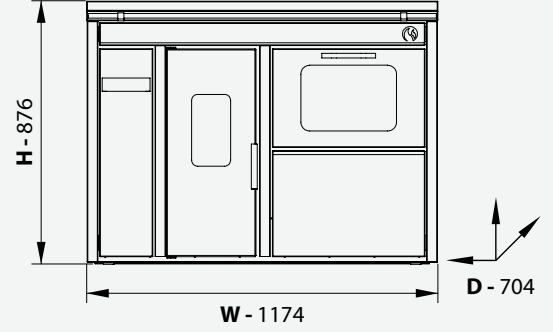

 22 - 6,6 kW	 14 kW	 8 kW	 92,6 - 95,7 %
 4,9 - 1,47 kg / h	 26 - 43 kg - lt	 265 kg	 Ø 100 mm

RENK

- Modülasyonlu yanma
- Dijital kontrol paneli ve Türkçe menü
- Otomatik ateşleme
- Tam otomatik temizlenen yanma potası
- Manuel tübülötör temizleme sistemi
- Bacadan emiş ile yanma
- Haftalık programlama
- Oda termostat bağlantısı
- Geriye yanma koruma
- Seran cam üzeri yemek pişirme
- Geniş, kullanışlı krom fırın
- Soft close fırın kapağı • Şömüne görünümü
- Kalorifer sistemi
- Sıcak su eşanjörü (opsiyonel)
- Wi-Fi - Kablosuz bağlantı (opsiyonel)
- Pelet yakıtlı

A+

DM186 Class 5

%100
yeşil enerji

PELET
SİSTEM

MODERN TASARIM
ÇAĞDAŞ ISINMA
ÇÖZÜMLERİ



CE EN 16510 BlmSchV 2



CONTO
TERMICO 2.0

GALATA STANDART

KALORİFERLİ PELET KUZİNESİ

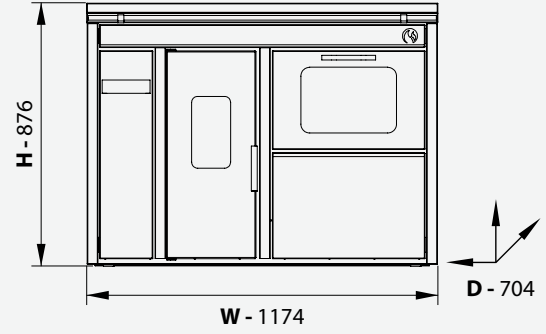

RENK



 22 - 6,6 kW	 14 kW	 8 kW	 92,6 - 95,7 %
 4,9 - 1,47 kg / h	 26 - 43 kg - lt	 265 kg	 Ø 100 mm

ÜRÜN ÖZELLİKLERİ

- Modülasyonlu yanma
- Dijital kontrol paneli ve Türkçe menü
- Otomatik ateşleme
- Manuel tübülötör temizleme sistemi
- Bacadan emiş ile yanma
- Haftalık programlama
- Oda termostat bağlantısı
- Geriye yanma koruma
- Üst saç üzerinde yemek pişirme
- Geniş, kullanışlı krom fırın
- Soft close fırın kapağı • Şömüne görünümü
- Kalorifer sistemi
- Sıcak su eşanjörü (opsiyonel)
- Wi-Fi - Kablosuz bağlantı (opsiyonel)
- Pelet yakıtlı

A⁺

DM186 Class 5

%100
yeşil enerji

PELET
SİSTEM

MODERN TASARIM
ÇAĞDAŞ ISINMA
ÇÖZÜMLERİ

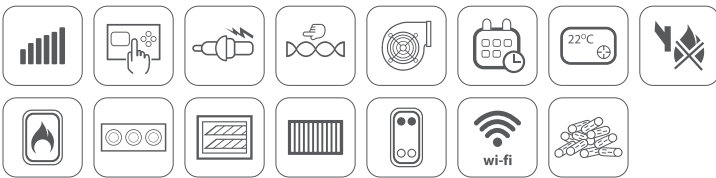

CE EN 16510 BImSchV 2



CONTO
TERMICO 2.0

RUMELİ

SICAK HAVA ÜFLEMELİ, PELET YAKITLI KUZİNE



RENK

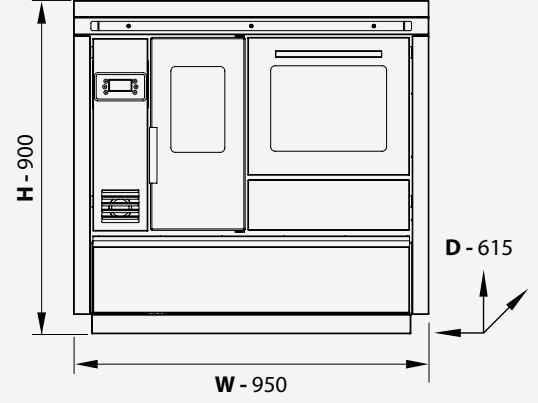

 9 - 3,8 kW	 86,6 - 88,1 %	 1,9 - 0,6 kg / h	 15 - 26 kg - lt
 156 kg	 Ø 80 mm	(*) Cihazın kuruluğu ortam şartlarına göre maksimum ısıtma hacmi değişiklik gösterebilir.	

ÜRÜN ÖZELLİKLERİ

- Modülasyonlu yanma
- Dijital kontrol paneli ve Türkçe menü
- Otomatik ateşleme
- Manuel temizlenen yanma potası
- Bacadan emiş ile yanma
- Haftalık programlama
- Oda termostat bağlantısı
- Geriye yanma koruma
- Seran cam üzeri yemek pişirme
- Soft close fırın kapağı
- Geniş, kullanışlı krom fırın
- Ortama sıcak hava üfleme desteği
- Hava kanalı ile çoklu ortam ısıtma imkanı
- Şömine görünümü
- Wi-Fi - Kablosuz bağlantı (opsiyonel)
- Pelet yakıtlı

A+

%100
yeşil enerji



PELET
SİSTEM

MODERN TASARIM
ÇAĞDAŞ ISINMA
ÇÖZÜMLERİ



CE EN 16510

EFES TRIO

SICAK HAVA ÜFLEMELİ, PELET YAKITLI SOBA



Hava kanalı
desteği ile
çoklu ortam
ısıtma imkanı

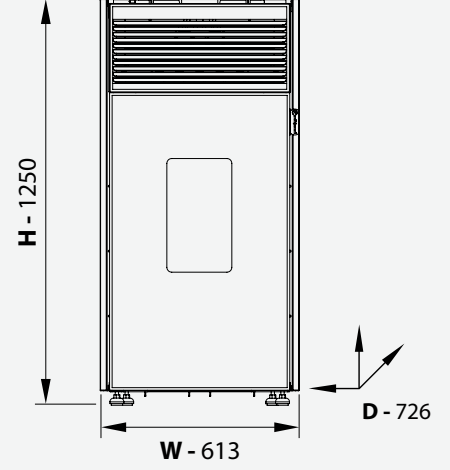

 16,3 - 3,2 kW	 87 - 90 %	 3,8 - 0,92 kg / h	 410 (*) m ³
 30 - 52 kg - lt	 192 kg	 Ø 80 mm	(*) Cihazın kurulduğu ortam şartlarına göre maksimum ısıtma hacmi değişiklik gösterebilir.

RENK

ÜRÜN ÖZELLİKLERİ

- Modülasyonlu yanma
- Dijital kontrol paneli ve Türkçe menü
- Otomatik ateşleme
- Manuel temizlenen yanma potası
- Bacadan emiş ile yanma
- Haftalık programlama
- Oda termostat bağlantısı
- Geriye yanma koruma
- Ortama sıcak hava üfleme desteği
- Hava kanalı desteği ile çoklu ortam ısıtma imkanı (3 Fanlı)
- Şömine görünümü
- Wi-Fi - Kablosuz bağlantı (opsiyonel)
- Pelet yakıtlı

A⁺

%100
yeşil enerji

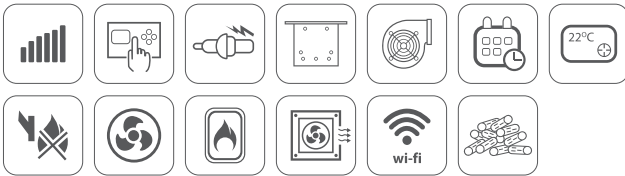

PELET
SİSTEM

MODERN TASARIM
ÇAĞDAŞ ISINMA
ÇÖZÜMLERİ



CE EN 14785

EFES COMFORT

SICAK HAVA ÜFLEMELİ, PELET YAKITLI SOBA

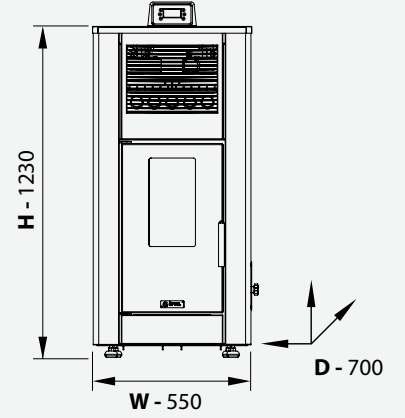

 12,2 - 5,1 kW	 85,6 - 94,4 %	 1,1 - 2,9 kg / h	 310 ^(*) m³
 23 - 38 kg - lt	 149 kg	 Ø 80 mm	<small>(*) Cihazın kurulduğu ortam şartlarına göre maksimum ısıtma hacmi değişiklik gösterebilir.</small>

RENK

ÜRÜN ÖZELLİKLERİ

- Modülasyonlu yanma
- Dijital kontrol paneli ve Türkçe menü
- Otomatik ateşleme
- Manuel temizlenen yanma potası
- Bacadan emiş ile yanma
- Haftalık programlama
- Oda termostat bağlantısı
- Geriye yanma koruma
- Ortama sıcak hava üfleme desteği
- Hava kanalı desteği ile çoklu ortam ısıtma imkanı (2 Fanlı)
- Şömine görünümü
- Wi-Fi - Kablosuz bağlantı (opsiyonel)
- Pelet yakıtlı

A+
DM186 Class 5

%100
yeşil enerji

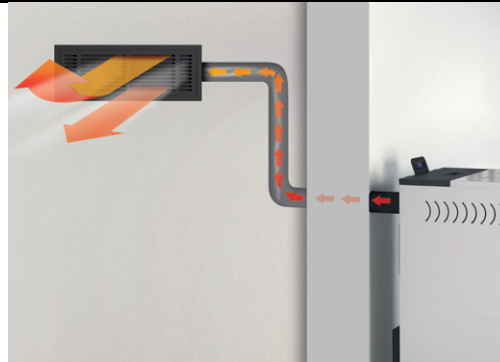

PELET SİSTEM

MODERN TASARIM
ÇAĞDAŞ ISINMA
ÇÖZÜMLERİ



CE EN 14785 BlmSchV 2 DM186 CONTO TERMICO 2.0

EFES PLUS

SICAK HAVA ÜFLEMELİ, PELET YAKITLI SOBA

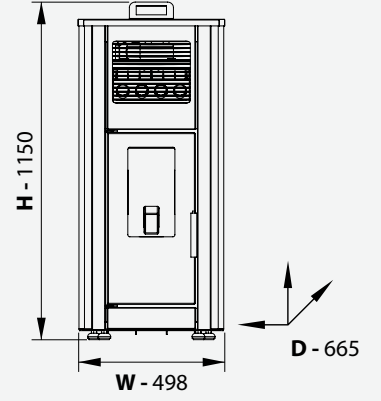

 10 - 3 kW	 10-12 kW	 88 - 89 %	 2,5 - 0,75 kg / h
 287 (*) m³	 23 - 38 kg - lt	 137 kg	 Ø 80 mm

(*) Cihazın kurulduğu ortam şartlarına göre maksimum ısıtma hacmi değişiklik gösterebilir.

RENK



ÜRÜN ÖZELLİKLERİ

- Modülasyonlu yanma
- Dijital kontrol paneli-Türkçe menü
- Otomatik ateşleme
- Manuel temizlenen yanma potası
- Bacadan emiş ile yanma
- Haftalık programlama
- Oda termostat bağlantısı
- Geriye yanma koruma
- Ortama sıcak hava üfleme desteği
- Hava kanalı desteği ile çoklu ortam ısıtma imkanı (2 Fanlı)
- Şömine görünümü
- Wi-Fi-Kablosuz bağlantı (opsiyonel)
- Pelet yakıtlı

A+

DM186 Class 5

%100
yeşil enerji

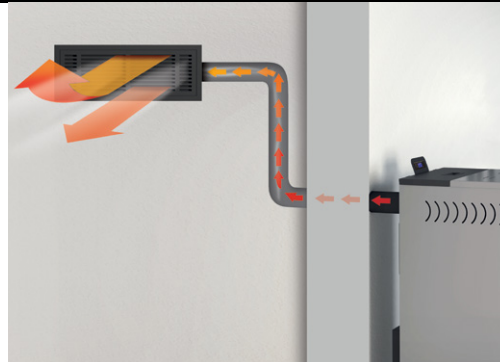
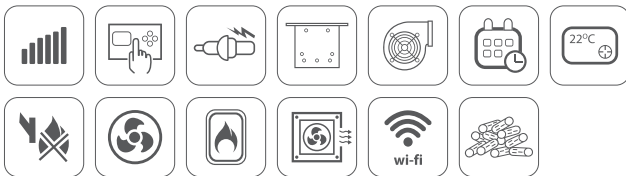

PELET
SİSTEM

MODERN TASARIM
ÇAĞDAŞ ISINMA
ÇÖZÜMLERİ



CE EN 14785 BlmSchV 2 DM186 CONTO TERMICO 2.0

GEDİZ STANDART

SICAK HAVA ÜFLEMELİ, PELET YAKITLI SOBA



Hava kanalı desteği ile çoklu ortam ısıtma imkanı.

(*) Cihazın kurulduğu ortam şartlarına göre maksimum ısıtma hacmi değişiklik gösterebilir.

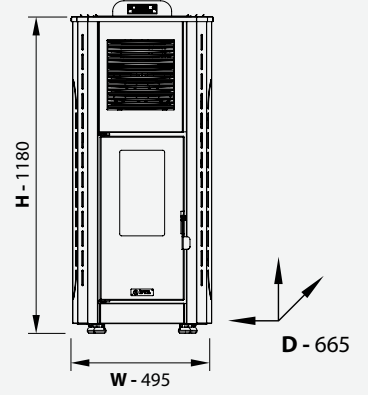

 8 - 2,4 kW	 8 - 10 kW	 88 - 89 %	 2,00 - 0,60 kg / h
 230 (*) m³	 17 - 28 kg - lt	 127 kg	 Ø 80 mm

RENK

ÜRÜN ÖZELLİKLERİ

- Modülasyonlu yanma
- Dijital kontrol paneli ve Türkçe menü
- Otomatik ateşleme
- Manuel temizlenen yanma potası
- Bacadan emiş ile yanma
- Haftalık programlama
- Geriye yanma koruma
- Ortama sıcak hava üfleme desteği
- Şömine görünümü
- Wi-Fi - Kablosuz bağlantı (opsiyonel)
- Pelet yakıtlı

A+

DM186 Class 5

%100
yeşil enerji

PELET
SİSTEM

MODERN TASARIM
ÇAĞDAŞ ISINMA
ÇÖZÜMLERİ

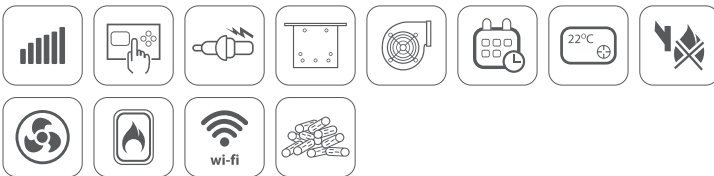

CE EN 14785 BlmSchV 2



CONTO
TERMICO 2.0

ADA

SICAK HAVA ÜFLEMELİ, PELET YAKITLI SOBA



RENK

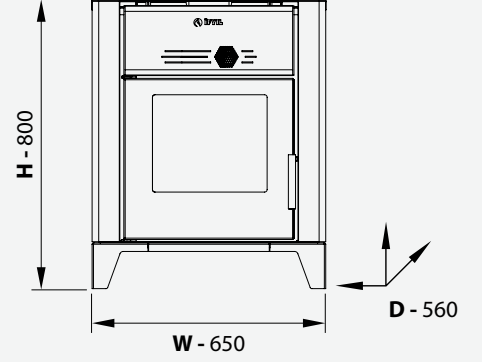

 5,3 - 1,2 kW	 85 - 89 %	 1,1 - 0,3 kg / h	 130 (*) m³
 15 - 26 kg - lt	 94 kg	 Ø 80 mm	

ÜRÜN ÖZELLİKLERİ

- Modülasyonlu yanma
- Dijital kontrol paneli ve Türkçe menü
- Otomatik ateşleme
- Manuel temizlenen yanma potası
- Bacadan emiş ile yanma
- Haftalık programlama
- Geriye yanma koruma
- Ortama sıcak hava üfleme desteği
- Şömine görünümü
- Wi-Fi - Kablosuz bağlantı (opsiyonel)
- Pelet yakıtlı

A+

%100
yeşil enerji

PELET
SİSTEM

MODERN TASARIM
ÇAĞDAŞ ISINMA
ÇÖZÜMLERİ

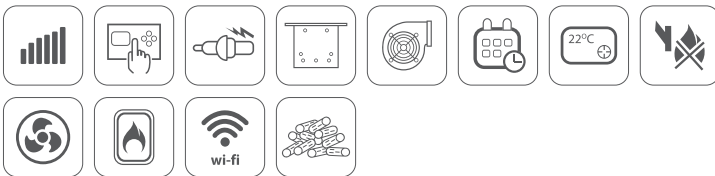

CE EN 14785

ZİGANA

KATI YAKITLI, KALORİFERLİ KUZİNE



RENK

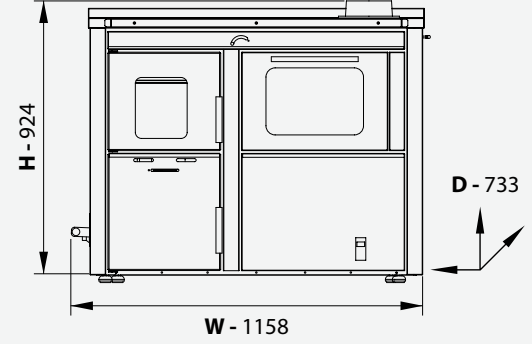

	Odun 23 kW	Briket 24 kW	Kömür 34,5 kW
	Odun 18 kW	Briket 18 kW	Kömür 27 kW
	Odun 5 kW	Briket 6 kW	Kömür 7,5 kW
	84,9 %		296 kg
			Ø 150 mm

ÜRÜN ÖZELLİKLERİ

- Devirmeli izgara temizleme sistemi
- Yarı otomatik birincil yanma havası kontrol
- Manuel ikincil yanma havası kontrol
- Emniyet ventili güvenlik tertibatı
- Üst tabla üzerinde yemek pişirme imkanı
- Geniş, kullanışlı krom fırın
- Şömine görünümü
- Önden ve üstten yüklemeli
- Kalorifer sistemi
- Sıcak su eşanjörü (opsiyonel)
- Odun, briket ve kömür yakma özelliği

A+

DM186 Class 5

**DÖRT
GÜÇLÜ
AVANTAJ**

KALORİFER, SICAK SU
SOBA & ŞÖMİNE

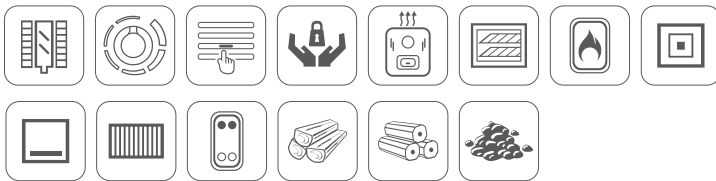

CE EN 16510 BImSchV 2



CONTO
TERMICO 2.0

AVANOS

KATI YAKITLI, KALORİFERLİ KUZİNE



RENK

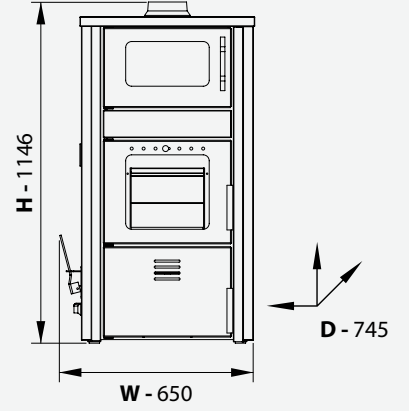

	Odun 20 kW	Briket 21 kW	Kömür 32 kW
	Odun 16 kW	Briket 17 kW	Kömür 26 kW
	Odun 4 kW	Briket 4 kW	Kömür 6 kW
	83 %		229 kg
			Ø 130 mm

ÜRÜN ÖZELLİKLERİ

- Devirmeli izgara temizleme sistemi
- Yarı otomatik birincil yanma havası kontrol
- Manuel ikincil yanma havası kontrol
- Emniyet ventili güvenlik tertibatı
- Üst tabla üzerinde yemek pişirme imkanı
- Geniş, kullanışlı krom fırın
- Şömine görünümü
- Önden yüklemeli
- Kalorifer sistemi
- Sıcak su eşanjörü (opsiyonel)
- Odun, briket ve kömür yakma özelliği

A⁺

DM186 Class 4

**DÖRT
GÜÇLÜ
AVANTAJ**

KALORİFER, SICAK SU
SOBA & ŞÖMİNE

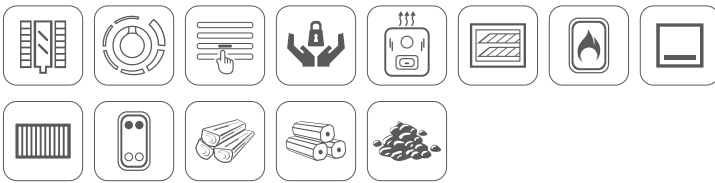

CE EN 16510 BImSchV 2







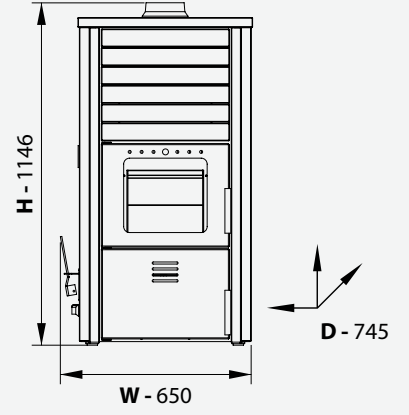

CONTO
TERMICO 2.0

ILGAZ

KATI YAKITLI, KALORİFERLİ SOBA



	Odun 29 kW	Briket 30 kW	Kömür 38 kW
	Odun 25 kW	Briket 26 kW	Kömür 34 kW
	Odun 4 kW	Briket 4 kW	Kömür 4 kW
	84 %		211 kg
			Ø 130 mm

RENK

ÜRÜN ÖZELLİKLERİ

- Devirmeli ızgara temizleme sistemi
- Yarı otomatik birincil yanma havası kontrol
- Manuel ikincil yanma havası kontrol
- Emniyet ventili güvenlik tertibatı
- Üst tabla üzerinde yemek pişirme imkanı
- Şömine görünümü
- Önden yüklemeli
- Kalorifer sistemi
- Sıcak su eşanjörü (opsiyonel)
- Odun, briket ve kömür yakma özelliği

A⁺

DM186 Class 4

**DÖRT
GÜÇLÜ
AVANTAJ**
KALORİFER, SICAK SU
SOBA & ŞÖMİNE



CE EN 16510 BImSchV 2



CONTO
TERMICO 2.0





TOROS PLUS

KATI YAKITLI, KALORİFERLİ SOBA

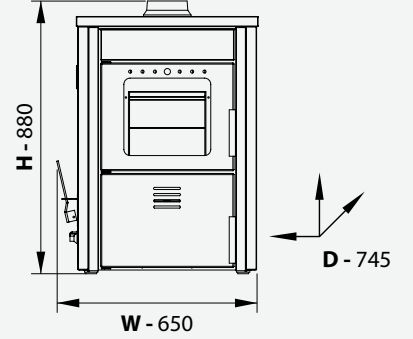

RENK



	Odun 20 kW	Briket 21 kW	Kömür 32 kW
	Odun 16 kW	Briket 17 kW	Kömür 26 kW
	Odun 4 kW	Briket 4 kW	Kömür 6 kW
	83 %		180 kg
			Ø 130 mm

ÜRÜN ÖZELLİKLERİ

- Devirmeli izgara temizleme sistemi
- Yarı otomatik birincil yanma havası kontrol
- Manuel ikincil yanma havası kontrol
- Emniyet ventili güvenlik tertibatı
- Üst tabla üzerinde yemek pişirme imkanı
- Şömine görünümü
- Önden ve üstten yüklemeli
- Kalorifer sistemi
- Sıcak su eşanjörü (opsiyonel)
- Odun, briket ve kömür yakma özelliği

A+

DM186 Class 4

**DÖRT
GÜÇLÜ
AVANTAJ**

KALORİFER, SICAK SU
SOBA & ŞÖMİNE



CE EN 16510 BImSchV 2



CONTO
TERMICO 2.0

TOROS STANDART

KATI YAKITLI, KALORİFERLİ SOBA



RENK

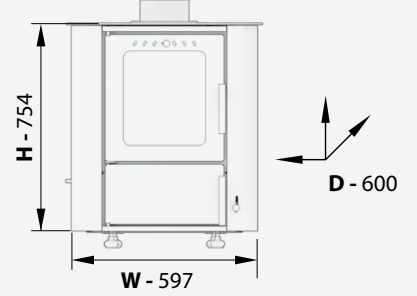

 kW	Odun 13 kW
 H ₂ O	Odun 10 kW
	Odun 3 kW
 %	80 %
 kg	90 kg
 Ø	Ø 130 mm

ÜRÜN ÖZELLİKLERİ

- Devirmeli izgara temizleme sistemi
- Yarı otomatik birincil yanma havası kontrol
- Manuel ikincil yanma havası kontrol
- Emniyet ventili güvenlik tertibatı
- Üst tabla üzerinde yemek pişirme imkanı
- Şömine görünümü
- Önden ve üstten yüklemeli
- Kalorifer sistemi
- Sıcak su eşanjörü (opsiyonel)
- Odun yakma özelliği

A⁺

DM186 Class 4

**DÖRT
GÜÇLÜ
AVANTAJ**

KALORİFER, SICAK SU
SOBA & ŞÖMİNE



CE EN 16510 BImSchV 2



CONTO
TERMICO 2.0

SÜMELA

KATI YAKITLI KUZİNE

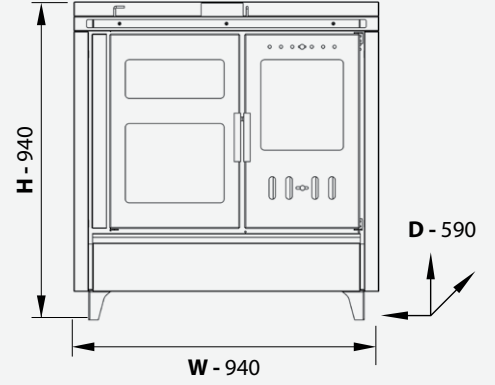

	Odun	Briket	Kömür
12,5 kW	12,5 kW	13,1 kW	13,6 kW

81,5 %	170 kg	Ø 130 mm

RENK

ÜRÜN ÖZELLİKLERİ

- Sürgülü ızgara temizleme sistemi
- Manuel birincil yanma havası kontrol
- Manuel ikincil yanma havası kontrol
- Üst tabla üzerinde yemek pişirme imkanı
- Geniş, kullanışlı krom fırın (2 Adet)
- Şömine görünümü
- Önden ve üstten yüklemeli
- Odun, briket ve kömür yakma özelliği
- Kanalize fan (opsiyonel)

A+

YENİ
ÜRÜN

ECO
DESIGN
2022



CE EN 16510





ÜRÜP

KATI YAKITLI KUZİNE

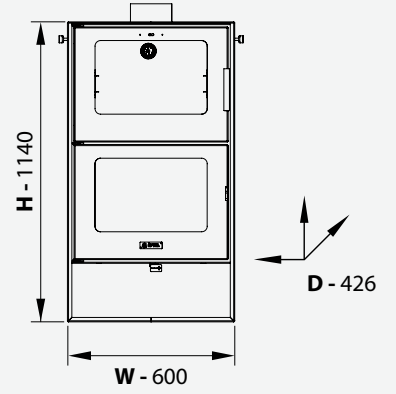

RENK



 kW	Odun 6,1 kW	Briket 7 kW	Kömür 7,6 kW
 %	80 %	 kg	125 kg
		 Ø	Ø 150 mm

ÜRÜN ÖZELLİKLERİ

- Manuel birincil yanma havası kontrol
- Manuel ikincil yanma havası kontrol
- Üst tabla üzerinde yemek pişirme imkanı
- Geniş, kullanışlı krom fırın
- Şömine görünümü
- Önden yüklemeli
- Odun, briket ve kömür yakma özelliği

A⁺

DM186 Class 4

YENİ
ÜRÜN

ECO
DESIGN
2022



CE EN 16510

GT 15 DELUXE

PELET YAKITLI KALORİFER KAZANI

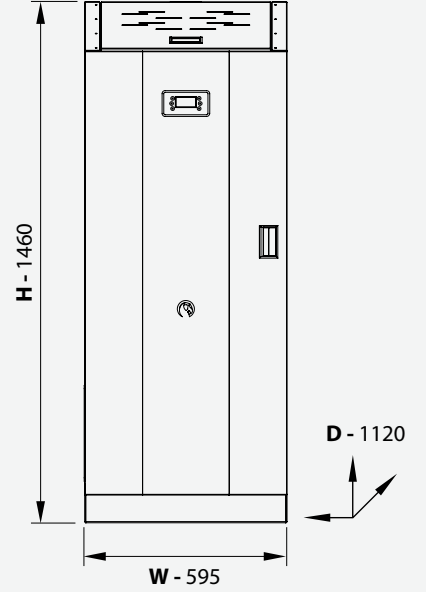

RENK

 15 - 4,5 kW	 15 kW	 91,53 - 91,64 %	 3,5 - 1,05 kg / h
 135 - 230 kg - lt	 231 kg	 Ø 100 mm	

ÜRÜN ÖZELLİKLERİ

- Modülasyonlu yanma
- Dijital kontrol paneli ve Türkçe menü
- Otomatik ateşleme
- Tam otomatik temizlenen yanma potası
- Manuel tübülötör temizleme sistemi
- Bacadan emiş ile yanma
- Haftalık programlama
- Oda termostat bağlantısı
- Geriye yanma koruma
- Kalorifer sistemi
- Sıcak su eşanjörü (opsiyonel)
- Wi-Fi - Kablosuz bağlantı (opsiyonel)
- Pelet yakıtlı
- Yaz ve Kış Modu (opsiyonel)

A⁺

EN 303-5 Class 5
DM186 Class 4

%100
yeşil enerji

PELET
SİSTEM

MODERN TASARIM
ÇAĞDAŞ ISINMA
ÇÖZÜMLERİ



EN 303-5

BlmSchV 2



CONTO
TERMICO 2.0

GT 25 DELUXE

PELET YAKITLI KALORİFER KAZANI



RENK

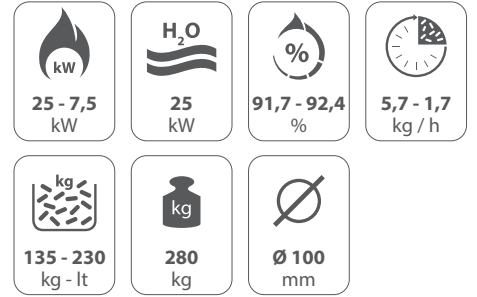
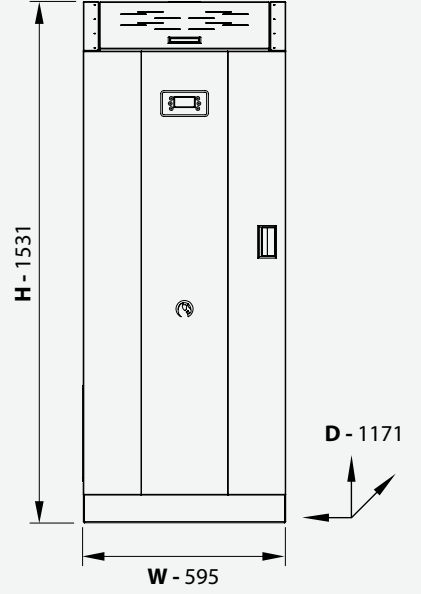

ÜRÜN ÖZELLİKLERİ

- Modülasyonlu yanma
- Dijital kontrol paneli ve Türkçe menü
- Otomatik ateşleme
- Tam otomatik temizlenen yanma potası
- Manuel türbülötör temizleme sistemi
- Bacadan emiş ile yanma
- Haftalık programlama
- Oda termostat bağlantısı
- Geriye yanma koruma
- Kalorifer sistemi
- Sıcak su eşanjörü (opsiyonel)
- Wi-Fi - Kablosuz bağlantı (opsiyonel)
- Pelet yakıtlı
- Yaz ve Kış Modu (opsiyonel)

A+

EN 303-5 Class 5
DM186 Class 4

%100
yeşil enerji

PELET
SİSTEM

MODERN TASARIM
ÇAĞDAŞ ISINMA
ÇÖZÜMLERİ



BlmSchV 2



CONTO
TERMICO 2.0

GT 34 DELUXE

PELET YAKITLI KALORİFER KAZANI

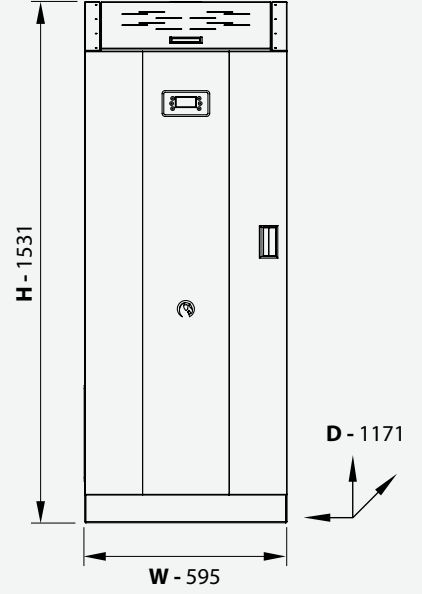

RENK

 34 - 10,2 kW	 34 kW	 83,5 - 85 %	 2,4 - 7,1 kg / h
 135 - 230 kg - lt	 280 kg	 Ø 100 mm	

ÜRÜN ÖZELLİKLERİ

- Modülasyonlu yanma
- Dijital kontrol paneli ve Türkçe menü
- Otomatik ateşleme
- Tam otomatik temizlenen yanma potası
- Manuel tübülator temizleme sistemi
- Bacadan emiş ile yanma
- Haftalık programlama
- Oda termostat bağlantısı
- Geriye yanma koruma
- Kalorifer sistemi
- Sıcak su eşanjörü (opsiyonel)
- Wi-Fi - Kablosuz bağlantı (opsiyonel)
- Pelet yakıtlı
- Yaz ve Kış Modu (opsiyonel)

A⁺

EN 303-5 Class 5
DM186 Class 4

%100
yeşil enerji

PELET
SİSTEM

MODERN TASARIM
ÇAĞDAŞ ISINMA
ÇÖZÜMLERİ



BlmSchV 2



CONTO
TERMICO 2.0

GT 40

PELET YAKITLI KALORİFER KAZANI



RENK

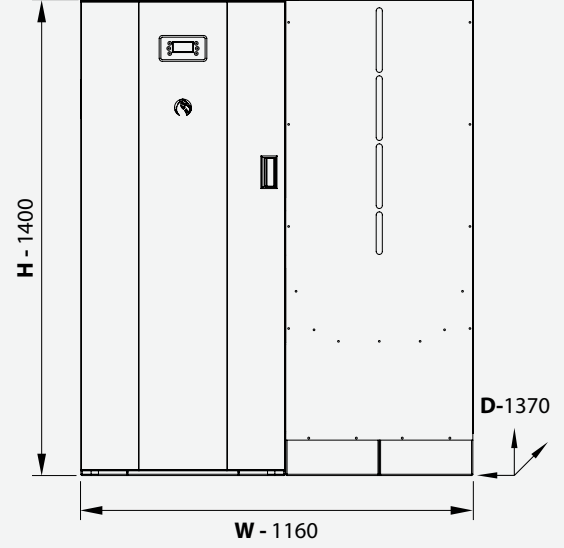

 40 - 12 kW	 40 kW	 92 - 93,1 %	 9,35 - 2,7 kg / h
 253 - 420 kg - lt	 310 + 100 kg	 Ø 100 mm	

ÜRÜN ÖZELLİKLERİ

- Modülasyonlu yanma
- Dijital kontrol paneli ve Türkçe menü
- Otomatik ateşleme
- Tam otomatik temizlenen yanma potası
- Otomatik türbülötör temizleme sistemi
- Bacadan emiş ile yanma
- Haftalık programlama
- Oda termostat bağlantısı
- Geriye yanma koruma
- Kalorifer sistemi
- Wi-Fi - Kablosuz bağlantı (opsiyonel)
- Pelet yakıtlı
- Yaz ve Kış Modu (opsiyonel)

A⁺

EN 303-5 Class 5
DM186 Class 4

%100
yeşil enerji

PELET
SİSTEM

MODERN TASARIM
ÇAĞDAŞ ISINMA
ÇÖZÜMLERİ



BlmSchV 2



CONTO
TERMICO 2.0

GT 60

PELET YAKITLI KALORİFER KAZANI



RENK

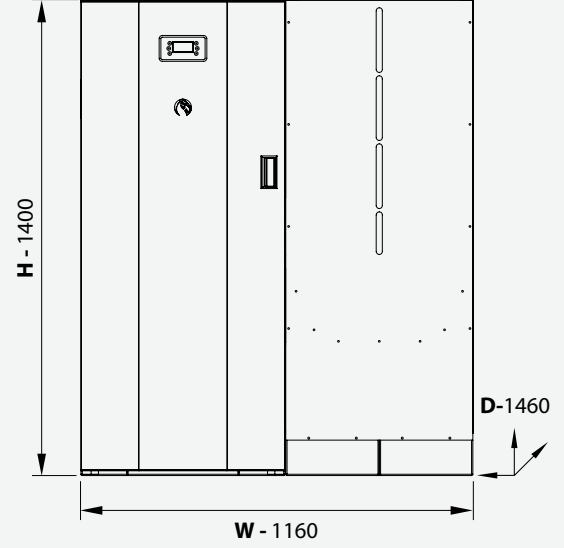

 60 - 18 kW	 60 kW	 92 - 94,19 %	 14 - 4,2 kg / h
 340 - 567 kg - lt	 424 + 107 kg	 Ø 130 mm	

ÜRÜN ÖZELLİKLERİ

- Modülasyonlu yanma
- Dijital kontrol paneli ve Türkçe menü
- Otomatik ateşleme
- Tam otomatik temizlenen yanma potası
- Otomatik türbülötör temizleme sistemi
- Bacadan emiş ile yanma
- Haftalık programlama
- Oda termostat bağlantısı
- Geriye yanma koruma
- Kalorifer sistemi
- Wi-Fi - Kablosuz bağlantı (opsiyonel)
- Pelet Yakıtlı
- Yaz ve Kış Modu (opsiyonel)

A⁺

EN 303-5 Class 5
DM186 Class 4

%100
yeşil enerji

PELET
SİSTEM

MODERN TASARIM
ÇAĞDAŞ ISINMA
ÇÖZÜMLERİ



BlmSchV 2







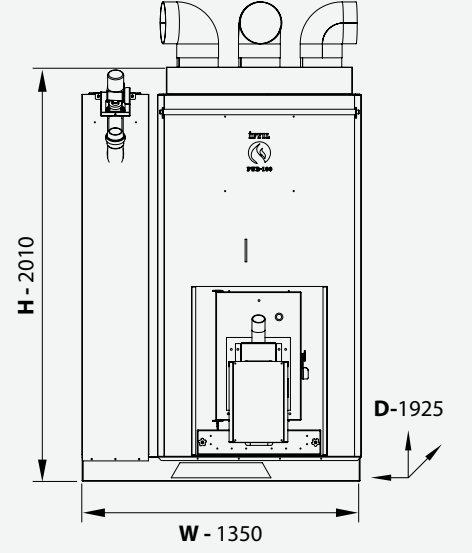

CONTO
TERMICO 2.0

PWR 100

SANAYİ TİPİ SICAK HAVA KAZANI



 100 - 30 kW	 90,5 - 91,5 %	 17,5 - 5,5 kg / h
 200 - 366 kg - lt	 550 kg	 Ø 130 mm

RENK

ÜRÜN ÖZELLİKLERİ

- Modülasyonlu yanma
- Dijital kontrol paneli ve Türkçe menü
- Otomatik ateşleme
- Tam otm. temizlenen yanma potası (opsiyonel)
- Manuel türbülator temizleme sistemi
- Bacadan emiş ile yanma
- Haftalık programlama
- Oda termostat bağlantısı
- Geriye yanma koruma
- Wi-Fi - Kablosuz bağlantı (opsiyonel)
- Pelet yakıtlı

A+

%100
yeşil enerji

PELET
SİSTEM

MODERN TASARIM
ÇAĞDAŞ ISINMA
ÇÖZÜMLERİ



CE EN 303-5

PWR SERİSİ

DIŞTAN TAKMALI PELET BRÜLÖR



Pelet dönüşümünde
ideal çözüm sunar...

RENK

ÜRÜN ÖZELLİKLERİ

- Uzun ömürlü
- Modülasyonlu yanma
- Kolay temizlik & bakım
- Otomatik ateşleme
- Yüksek verim ve düşük emisyon
- Yüksek termal yüklerle dayanıklı ve değiştirilebilir ızgara
- Değiştirilebilir ve gövdeye kaynaklı yapıda namlu
- Eğimli pelet ızgarası sayesinde yakıtın homojen dağılımı
- Geri yanma kontrolü,
- Brülör kutusuna entegre hava fanı
- Dijital kontrol paneli
- Yüksek sıcaklığa dayanıklı özel paslanmaz çelik nozul
- Kompresörlü otomatik kül temizleme kiti (Opsiyonel)



Dijital Kontrol Paneli

Maksimum yakıt tasarrufunu sağlamak amacıyla dijital kontrol paneli ile tasarlandı..

VERA

ELEKTRİKSİZ PELET YAKITLI MANGAL & BARBEKÜ



ÜRÜN ÖZELLİKLERİ

- Renk : Bordo, Yeşil, Simli Siyah
- Tür : Elektriksiz Pelet Yakıtlı Mangal & Barbekü
- Kullanım Yeri : Açık Alan, Teras, Açık Balkon
- Boyutları : 38,6x38,6x28,6 cm
- Maximum Yüzey Sıcaklığı : 300 derece
- Geniş Izgara Alanı : 38,6x38,6 cm
- Pişirme Kapasitesi : 1490 cm²
- Pişirme Kişi Sayısı : 6 – 8 Kişi
- Izgara Özelliği : Döküm Demir
- Gövde : Çelik
- Yakıt Haznesi : 2,1 kg
- Yakıt Tüketimi : 1,2 Kg/Saat
- Kül Haznesi : Var
- Kapak : Opsiyonel
- Ocak Başlığı : Var
- Ağırlık (Kapak, Izgara Hariç) : ~9 kg



RENK



CE EN 303-5



YENİLENEBİLİR enerji

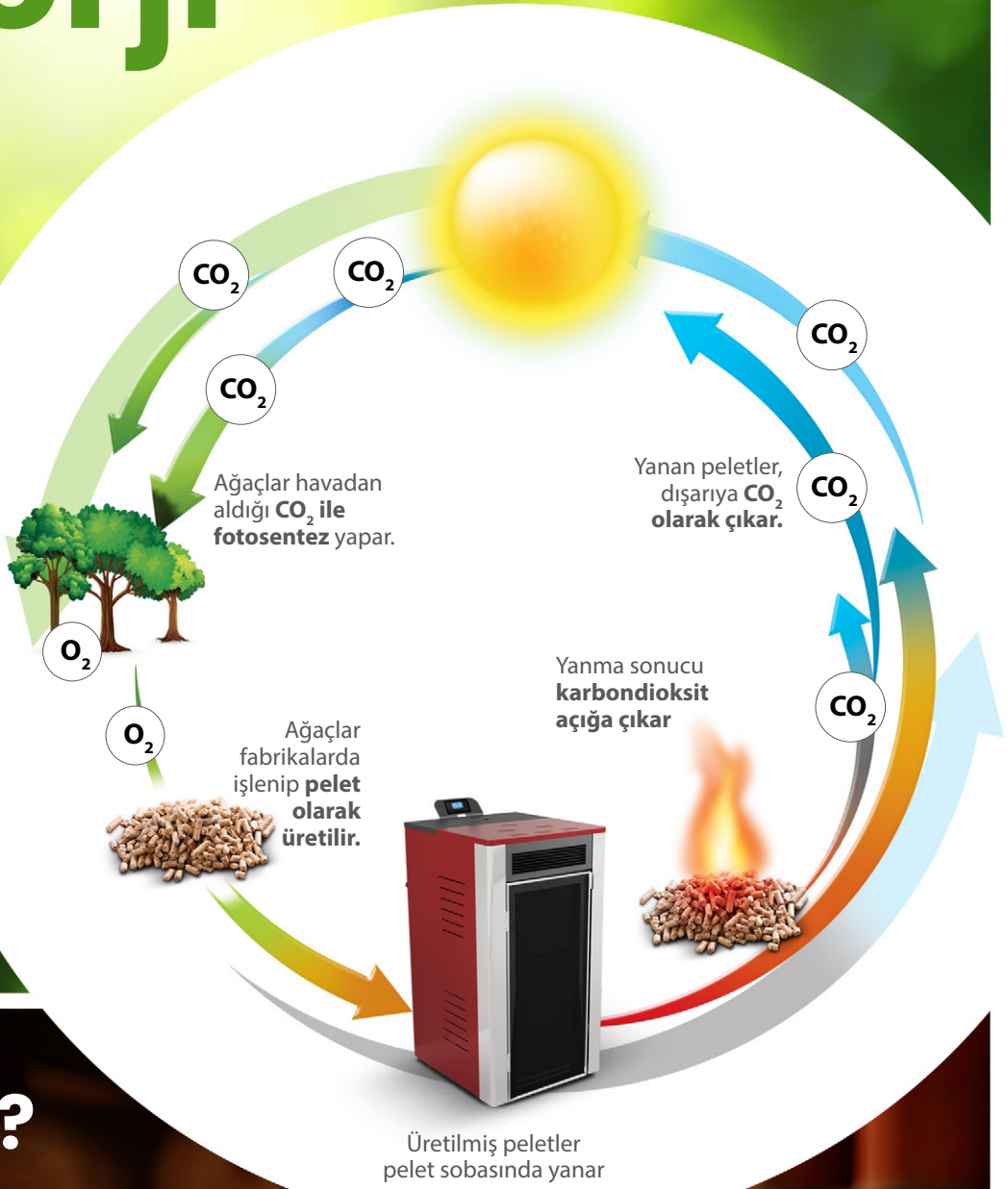

Pelet Nedir?

Pelet; ormansal ve bitkisel artıkların öğütülerek talaş tozu haline getirildikten sonra, yüksek basınçla preslenerek sıkıştırılması ile oluşturulan enerji elde etmek amacıyla kullanılan yakıt parçacıklarıdır. Küçük silindirik bir forma sahip olan, genellikle 6-10 mm çapında ve 10-50 mm arasında uzunluğu olan yakıt türüdür.



“Sağlıklı ve Kaliteli Mekanlar için ifyıl”



Ekonomik ve Konforlu...

İfyıl sobalarının yakıt maliyeti normal sobanın yakıt maliyetine yakındır. İfyıl'ın farkı ise, normal sobaya göre sadece bir odayı değil, evin her tarafını radyatörler vasıtasıyla eşit ısıtmasıdır. Evinizin her yerinde eşit sıcaklığı sağlarken, banyo, lavabo ve mutfağınızda sıcak suyun keyfini çıkartacaksınız!...

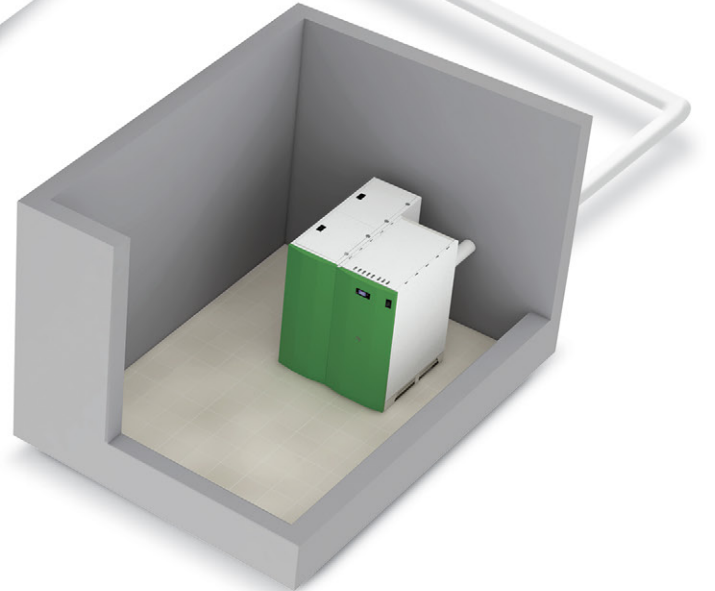

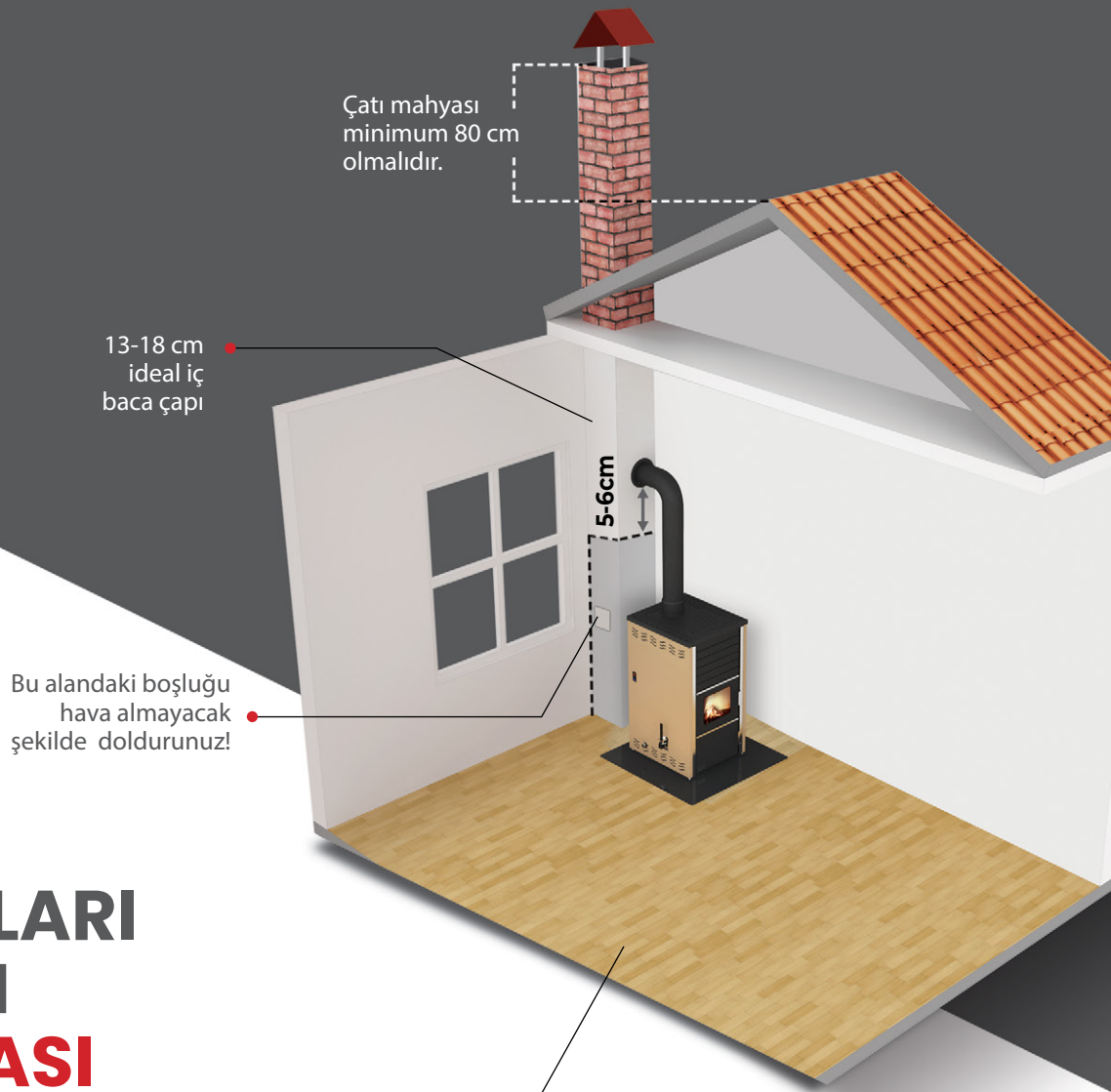

İFYIL SOBALARI İÇİN UYGUN BACA ŞEMASI

 **İFYIL**[®]
"ortam ısıtıcınız"



Katalogda meydana gelebilecek tipografik hatalardan ve renk kayıplarından firmamız sorumlu değildir. İfyıl, ürünlerinde değişiklik yapma hakkını saklı tutar.

YEŞİL ENERJİYİ SEÇMEK



2024
COLLECTION



**ifyil Termo İklimlendirme
San. ve Tic. Ltd. Şti.**



Kavak Organize Sanayi Bölgesi 3. Cadde
No.11 Kavak | Samsun | Türkiye

T +90 850 346 0362
www.ifyil.com.tr

f @ y in d
info@ifyil.com.tr

